

Urban Forests



A Supplement to Florida's Project Learning Tree

Bebette de Vera, Martha C. Monroe, and Jennifer A. Seitz^{1,2}
School of Forest Resources and Conservation, University of Florida

Acknowledgements

We thank the following people for their advice and assistance during the initial development of this project: Maureen Austin, Christine Kelly-Begazo, Mary Ford, Kim Gabel, Roberta Harbrucker, Ricky Quintana and Stan Rosenthal.

We are grateful to the following educators and advisors who reviewed this supplement to PLT:

Abdu Salaam Moulta Ali	Urban Naturalist Educator, Eagle Eye Institute
Dr. Behar-Hornstein	Professor, Curriculum Theory & Research, University of Florida
Lucy Cortese	Executive Director, Tree Hill Jacksonville
Dr. Linda Cronin-Jones	Professor Science Education, University of Florida
Marina D'Abreau-Pryce	Extension Agent, Hillsborough County
Janice Easton	Former PLT Coordinator for Florida
Eliana Kampf	Project Coordinator, University of Florida
Dr. Mary Leou	Professor, Environmental Education, New York University
Dr. Alan Long	Professor, Forest Operations, Extension, University of Florida
Dr. Lee Mullally	Professor, Instructional Design, University of Florida
Eric Smith	Urban Forester, University of Florida
Raymond Zerba	Extension Agent, Clay County
Dr. Wayne Zipperer	Urban Forest Scientist, USDA Forest Service

The following graduate students and staff at the School of Forest Resources and Conservation, University of Florida, participated in the initial testing of this educational material: Shruti Agrawal, Anna Behm, Kristy Bender, Trina Hofreiter, Holly Johnson-Shiralapour, Terri Mashour, Lauren McDonell, Jensen Momtambault, Cotton Randall, and Deoyani Sarkhot.

The authors thank Michele Linette for her assistance in designing the supplement.

Special thanks to Dr. Wayne Zipperer at the USDA Forest Service's Southern Center for Wildland-Urban Interface Research and Information Station. He greatly improved this project by providing access to resources, assessing the accuracy of information and offering constructive feedback.

This material has been prepared with USDA Forest Service Urban and Community Forestry grant funds received through the Florida Division of Forestry, and resources from the School of Forest Resources and Conservation and the College of Agriculture and Life Science at the University of Florida; and International Paper Company.

Copyright Information

This document is copyrighted by the University of Florida, Institute of Food and Agricultural Sciences (UF/IFAS) for the people of the State of Florida. UF/IFAS retains all rights under all conventions but permits free reproduction by all agents and offices of the Cooperative Extension Service and the people of the State of Florida. Permission is granted to others to use these materials in part or in full for educational purposes, provided that full credit is given to the UF/IFAS, citing the publication, its source, and date of publication.

1. This document is CIR 1457, School of Forest Resources and Conservation, Florida Cooperative Extension Service, Institute of Food and Agricultural Sciences, University of Florida. Original publication date October 2004. Visit the EDIS Web site at <http://edis.ifas.ufl.edu>.
2. Bebette de Vera, Graduate Student; Martha C. Monroe, Associate Professor; and Jennifer A. Seitz, Project Learning Tree State Coordinator; School of Forest Resources and Conservation, Florida Cooperative Extension Service, Institute of Food and Agricultural Sciences, University of Florida, Gainesville, 32611.

Table of Contents

Overview	v
What is an urban forest?.....	v
How can we maximize urban forest benefits in Florida?.....	v
How can students benefit from learning in green spaces?	vi
How can PLT help teachers?	vi
Which teaching method should I use?	vi
How to Use This Supplement	vi
Section 1: Conceptual framework.....	3
Section 2: Activities matrix.....	7
Section 3:	
Goal One Activities.....	11
Goal Two Activities.....	23
Goal Three Activities	49
Section 4: Urban forest resources.....	75
Urban forest glossary of terms	77

Overview

The purpose of this educational guide is to supplement the *Project Learning Tree® (PLT) Environmental Education Activity Guide for PreK-8* grades so an urban educator has the tools to help students understand Florida's urban forest. It does this by identifying 26 PLT activities that can be used in urban areas; 19 PLT activities that can be changed slightly to be more applicable to an urban space; 6 extensions to existing PLT activities; and 6 new activities. We hope these 57 activities will help you provide a comprehensive study of the urban forest.

What is an urban forest?

The trees around our homes, on our streets, in our parking lots, beside our schools, and throughout our parks are part of an urban forest. The urban forest is made up of trees and other vegetation within the built environment. It is highly influenced by people and other factors, such as vehicles, buildings, pavement, utility lines, underground pipes, animals, and other plants.

Florida's forests cover 16.2 million acres or 47% of its total land base. These renewable and dynamic resources are undergoing significant pressure from a dramatically increasing Florida population. Since 1987, the forestland base has decreased by 41,500 acres per year, with over 50% of the decrease associated with urban growth. As the area of natural and planted forestland in the state declines, the urban forest increases.

Thanks to Florida's subtropical climate, our urban forest hosts a rich diversity of trees. While longleaf pine and live oaks are common trees in north Florida's urban areas, palms, cycads, jacarandas, and sea grape are more common in the south. Florida's urban forests can include slash and longleaf pine trees growing on the outskirts of Tallahassee, crape myrtles lining boulevards in Lakeland, live oaks and Sabal palms in Tampa, or orange and papaya trees growing in Miami backyards.

How can we maximize urban forest benefits in Florida?

Urban forests can help mitigate the negative effects of urban development. They can curb air pollution, improve water quality, lower heating and cooling costs, minimize storm water runoff, decrease soil erosion, lessen the urban heat island effect, buffer noise pollution, provide habitat for wildlife, increase property values, and contribute to the psychological and social health of communities. These urban trees and other vegetation make a daily difference to the quality of life for the 80 percent of the U.S. population who live in urban areas.

Despite these benefits, the urban forest also poses risks to residents and property. When exposed to hurricanes and tropical storms, urban trees can lose branches and topple over, bringing down powerlines, tearing up water mains, and damaging anything in the way. We can design and maintain urban forests to better withstand high winds, however. Planting species that have greater wind resistance, pruning them with care, and removing trees with poor wind resistance can help improve the urban forest's capacity in a storm. Planting trees in the best location and providing appropriate water and nutrients are also important.

Wind resistance is a function of tree characteristics such as form, size, trunk, branches and root system, wood density, leaf size, and a few environmental characteristics like depth to water table and surrounding structures. The faster the winds blow, the greater the chance a tree will break or fall. Trees like live oak, magnolia, and cabbage palm tend to do better than red maple, water oak, and queen palm for example, though no tree is absolutely wind proof.

Proper planting plays an important role in maintaining a healthy urban forest. For instance, a tree planted next to a building is left without adequate space for the roots to grow in one direction and is prone to blowing over. The installation of

sidewalks or roads may cut roots on one side of a tree, increasing the chance it will topple. Pruning is also very important to wind resistance. Trees that have been pruned on a regular basis have stronger and fewer branches and are less likely to fall than unpruned trees. Understanding the importance of these characteristics can assist urban dwellers in minimizing property damage and injury from trees falling over during storms.

Florida has seen tremendous changes in a short period of time due to our rapid population growth. Young people can play an important role in helping Florida's urban forests support environmental, social and economic goals in their towns and cities. We hope this urban forest supplement to PLT encourages urban youth to learn more about their neighborhood trees and see their community's urban forests as significant, valuable, and worth sustaining. You can help by teaching youth about their urban forests.

How can students benefit from learning in green spaces?

Recent research suggests green views and access to green spaces in urban areas help relieve the everyday pressures of crowding, noise, and stress. Playing and living near urban trees can be beneficial to all of us and can help children learn better in school. Teaching about urban forests helps build understanding about this important resource and also gives you an opportunity to use them as a learning site.

How can PLT help teachers?

The PLT Steering Committee understands that teachers in Florida are accountable to the new goals of our education reform efforts. In light of this, all PLT activities have been correlated to the Florida Sunshine State Standards to help teachers identify the relevant benchmarks. You can find that information on the PLT Web site:

<http://sfrc.ufl.edu/plt>.

Most of the new activities as well as the urban forest extensions to PLT are designed to promote scientific investigation consistent with Florida's new emphasis on science and Florida Comprehensive Assessment Tests in science. The use of science process skills helps students observe, measure, organize, analyze, think logically, and communicate. These skills help create a more scientifically and environmentally literate citizenry. As a result, the new activities and extensions are most appropriate for upper elementary and middle school youth.

Which teaching method should I use?

Teachers may find a structured inquiry approach to be the best teaching method for most of the new activities and urban forest extensions to PLT. Students are given a problem to investigate, procedures, and materials. Students collect data and discover relationships among variables or generalize information through discussion. With advance students who are more capable, the teacher could provide only the materials and the problem, allowing students to devise their own investigation in order to answer their questions.

Becoming aware of the urban forest is an important first step. Before you can improve your local environment you must first know what exists and then later investigate what is needed. Therefore, it is recommended that educators conduct the "Taking Inventory and Mapping" exercise first. If it is not possible to use all of the lessons, educators should try at least one activity from each of the three goals in the series. This will help students become aware of their urban forest, know why it is important, and have an opportunity to participate in its enhancement.

How to use this supplement

There are four sections in this Urban Forest supplement to PLT. Section 1 is the Conceptual Framework that guided the development of these

activities. Section 2 helps you choose activities that match your teaching goals. It references all 57 activities in an organizational chart categorizing activities into individual goals and conceptual themes. Section 3 includes 6 new activities, 6 extensions to existing PLT activities, and 19 suggested modifications to PLT that make it more applicable to exploring and understanding the urban forest. In Section 4, you can find supportive information such as a glossary of terms and a list of urban forest resources.

We are anxious to get feedback on this document and are looking for teachers to participate in a pilot test. Anyone who is interested in obtaining a free complimentary copy of this supplement should attend one of Florida's PLT workshops. For those who have already attended a PLT educator workshop, this supplement can be downloaded free of charge from the PLT Web site and EDIS system, <http://edis.ifas.ufl.edu>.

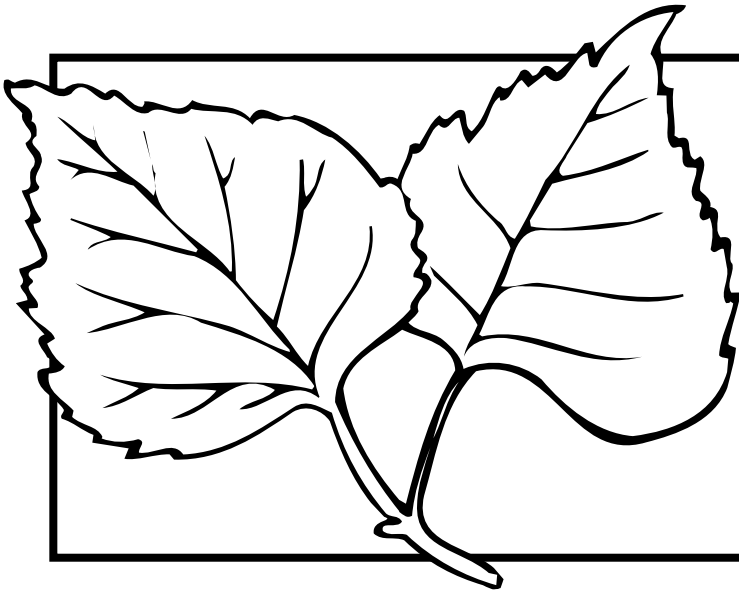

Section 1

Conceptual Framework

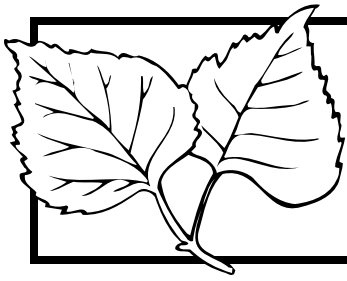

Conceptual Framework

Conceptual Framework

This conceptual framework identifies key urban forest concepts that can be attained under the following broad learning goals. The overall mission in this Urban Forest Supplement to Florida's PLT is to increase learner interest, understanding, and skills to enhance and sustain urban forests.

Goal 1: Increase youths' awareness of their urban forest ecosystem

Learning Goal: Students will learn about the ecology of their local forest habitat through observing, measuring, and finding patterns.

Concepts: Growth-Development, Mapping-Exploring, Urban Forest Ecology

- The urban forests are defined as all the trees, shrubs, and vegetation where people live, work, and play.
- Assessing the variety and number of trees in an urban area will enable students to obtain a better understanding of their urban environment.
- The amount of tree canopy relates to the extent an urban forest can influence the ecology of an area.

Goal 2: Increase youths' understanding of the benefits and costs of their urban forest

Learning Goal: Students will be able to explain the benefits provided by an urban forest.

Concepts: Benefits and Costs

- Tree root systems hold soil in place which reduces erosion, maintains urban waterways, and traps pollutants.
- Trees redistribute oxygen to the atmosphere through the process of photosynthesis.
- Tree leaves act as natural filters that remove particulates from the air.

- Urban trees store carbon dioxide.
- Trees reduce heating and cooling needs which decreases energy costs by shading and protecting structures.
- Trees offer protection from wind, ultraviolet light, and noise pollution.
- Urban forests provide some wildlife habitat.
- Fallen tree leaves return organic nutrients to the soil as they decompose.
- Trees contribute to the beauty of a neighborhood and increase property values.
- Urban residents receive psychological and social benefits from urban forests.
- Urban forests provide places to recreate and for a community to gather.
- Urban forests can be used for education.
- Urban forests require maintenance and care.

Goal 3: Engage youth in opportunities to monitor, maintain, and enhance the urban forest

Learning Goal: Students will be able to assess forest health and design activities to improve their community's urban forest.

Concepts: Forest Health, Community Projects

- An urban forest that functions well can provide environmental, social, and economic benefits to a community helping to mitigate the negative effects of urban development.
- Urban forests can indicate the health of the forest ecosystem.
- Infrastructure such as buildings, pavement, utility wires, or underground pipes that cut tree limbs and roots can affect tree health.
- The size, structure, and composition of the urban forest can be enhanced to support wildlife habitats.
- People have a direct effect on how urban forests are utilized, maintained, and conserved.

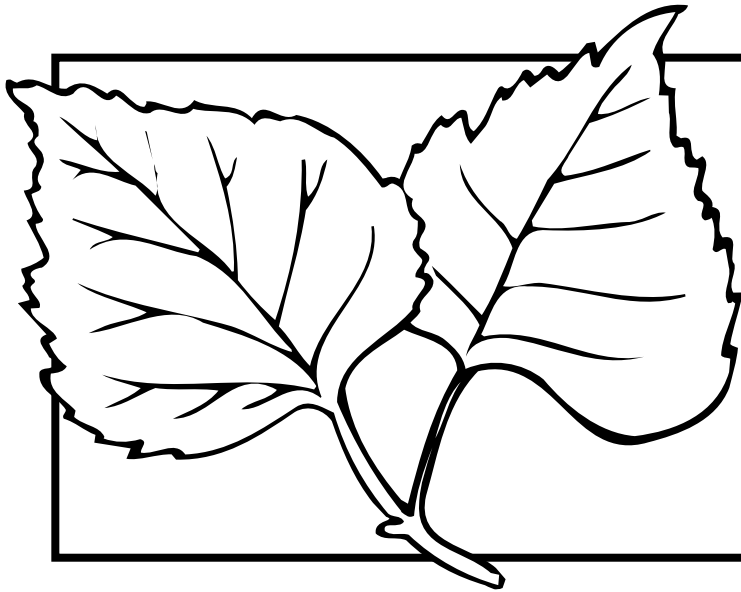

Section 2

Activities Matrix

The following organizational chart categorizes 56 activities that meet one of the broad goals in the urban forest conceptual framework. It identifies 26 activities that work well in the urban areas, 19 PLT activities that have suggestions to be more applicable to urban spaces, 6 urban forest extensions to existing PLT activities and 6 new activities.

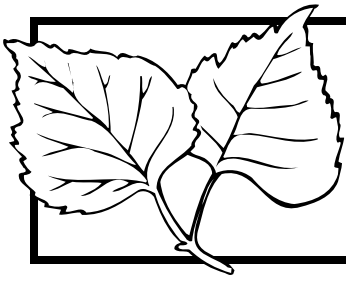

Activities Matrix

Goal 1: Urban Forest Ecosystem, Activities Matrix

PLT Activity	Activity Title	Growth and Development	Mapping and Exploring	Urban Forest Ecology
2	Get in Touch with Trees	✓		
3	Peppermint Beetle			✓
5	Poet-Tree	✓		
7	Habitat Pen Pals			M p 20
8	The Forest of S.T. Shrew			M p 20
10	Charting Diversity			M p 20
23	The Fallen Log			✓
24	Nature's Recyclers			✓
28	Air Plants			✓
30	Three Cheers for Trees			✓
40	Then and Now		✓	
41	How Plants Grow	✓		
42	Sunlight and Shades of Green	✓		
45	Web of Life			M p 20
46	School Yard Safari			✓
47	Are Vacant Lots Vacant?			✓
48	Field, Forest, and Stream		M p 20	
56	We Can Work It Out			✓
61	The Closer You Look	✓		
63	Tree Factory	✓		
64	Looking at Leaves	✓		
65	Bursting Buds	✓		
66	Germinating Giants			✓
67	How Big is Your Tree?		✓	
68	Name that Tree		✓	
71	Watch on Wetlands			✓
74	People, Places, Things		✓	
76	Tree Cookies	✓		
80	Nothing Succeeds like Succession			M p 20
95	Did you Notice?		M p 20	
New A	Inventorizing and Mapping		New p 11	
New B	Percent Canopy Cover		New p 17	

✓ = PLT Activity works well in an urban environment.

M = A modification is described on indicated page to make this PLT activity more applicable to an urban setting.

Ext = An activity extension is described on indicated page to make this PLT activity more applicable to an urban setting.

New = A new activity is described on indicated page for an urban setting.

Goal 2: Urban Forests Benefits and Costs, Activities Matrix

PLT Activity	Activity Title	Benefits and Costs
4	Sounds Around	✓
19	Viewpoints on the Line	M p 45
35	Loving It Too Much	M p 45
44	Water Wonders	Ext p 23
54	I'd Like to Visit a Place Where...	✓
91	In the Good Old Days	M p 45
92	A Look at Lifestyles	M p 45
New C	Urban Air Improvement	New p 29
New D	Tree Shadows	New p 31
New E	Investigating a Livable Community	New p 35
New F	Weighing Costs and Benefits	New p 41

✓ = PLT Activity works well in an urban environment.

M = A modification is described on indicated page to make this PLT activity more applicable to an urban setting.

Ext = An activity extension is described on indicated page to make this PLT activity more applicable to an urban setting.

New = A new activity is described on indicated page for an urban setting.

Goal 3: Urban Forest Opportunity for Action, Activities Matrix

PLT Activity	Activity Title	Forest Health	Community Projects
21	Adopt a Tree		✓
22	Trees as Habitats		Ext p 67
27	Every Tree For Itself	Ext p 61	
31	Plant a Tree		M p 71
33	Forest Consequences		M p 71
34	Who Works in This Forest?		Ext p 65
55	Planning the Ideal Community		M p 72
58	There Ought to be a Law		M p 72
59	Power of Print		M p 71
60	Publicize It!		M p 71
70	Soil Stories	Ext p 59	
77	Trees in Trouble	Ext p 49	
79	Tree Lifecycle		M p 71
96	Improve Your Place		M p 72

✓ = PLT Activity works well in an urban environment.

M = A modification is described on indicated page to make this PLT activity more applicable to an urban setting.

Ext = An activity extension is described on indicated page to make this PLT activity more applicable to an urban setting.

New = A new activity is described on indicated page for an urban setting.

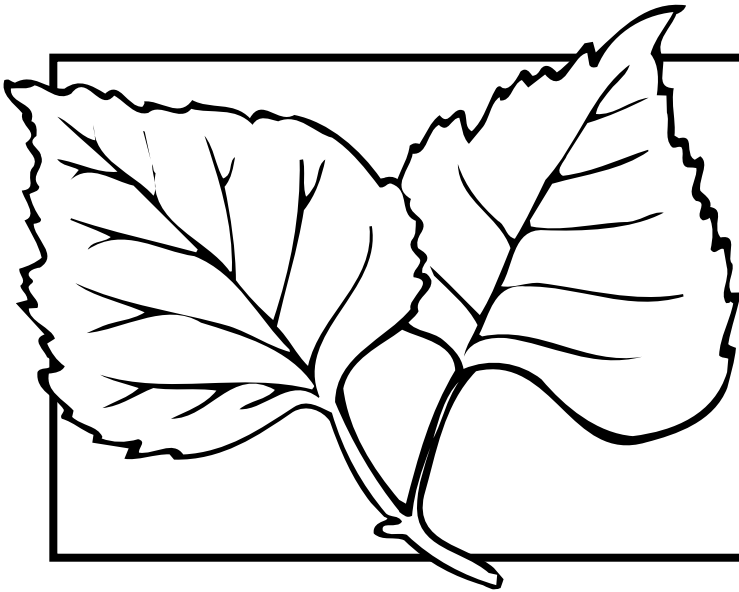

Section 3

Goal 1:

**Increase youths' awareness of
their urban forest ecosystem**

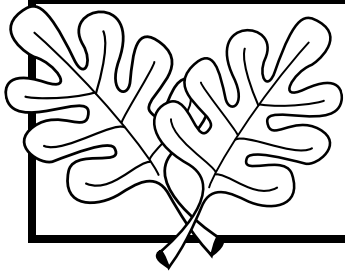

Inventorizing and Mapping

New activity A

Goal 1: Urban Forest Ecosystem

Concept: Mapping and Exploring

Overview

Tree inventorizing and mapping are important steps to become familiar with your urban forest. The information students gather from this inventory and the map they create will provide the foundation for many activities to follow.

Objectives

Students will be able to **1)** inventory trees in their area by recording tree names, height, diameter at breast height, and location; **2)** create frequency charts of three dominant species; and **3)** create a picture map of their study area to compare and contrast the distribution of trees and vegetation.

Materials

Inventory: Local map, tree identification book that also includes exotic species, pencils, measuring tape, clipboard, compass, calculator, data sheet, and protractor.

Mapping: Graph paper, pencils, large sheet of paper, markers, and scissors.

5 Flags: 5 wire hangers, tape, and 5 pieces of paper.

Background

Before students can make plans to understand, monitor, or potentially improve their urban environment they should first become aware of what exists. An urban forest is defined as the trees, shrubs, and other vegetation where people live, work, learn, and play. It is highly influenced by people, buildings, pavement, vehicles, animals, and other plants. It includes places such as schoolyards, street trees, neighborhood parks, vacant lots, and more.

A tree inventory is simply a list of trees and their characteristics. By doing an inventory, students will learn what kind of trees they have and how many are located at their site. Mapping local trees will enable students to know how they are distributed and become more familiar with their surroundings. In addition, educators can use this activity to assess what students know and have learned about their urban environment.

How to choose which trees to measure:

If your site is exceptionally large or has an abundance of trees, you can choose to work with a smaller area. However, choose a plot large enough to include a variety of species of trees of different sizes. We suggest choosing a study plot that is at least 100 feet by 100 feet. It is okay if your site is along a street or if it does not have a significant number of trees because this exercise can help youth assess and document the site.

Grade Level: 6 – 8

Time Considerations: 1-3 days

Subject Area: Math, Social Studies

Skills: Observing, Measuring, Comparing, Contrasting, Adding, Analyzing, and Concluding

Relevant Standards:

MA.B.3.3 – The student estimates measurements in real-world problem situation

MA.C.1.3 – The student describes, draws, identifies and analyzes two and three dimensional shapes

SS.B.1.3 – The student understands the world in spatial terms

Getting Ready

- 1) To optimize safety, the educator should assess the site for potential problems.
- 2) Note the size of the area and divide it into 4 equal quadrants to be studied.
- 3) Make flags by unwinding a metal hanger and tape 1 piece of paper to one end.
- 4) Place flags at the 4 corners of your site and the middle to help students distinguish their quadrant boundaries.
- 5) Number the trees that will be used in this inventory and sketch a simple map that will help students locate designated trees.
- 6) Practice reading and making maps.

Pre-Activity Questions

- 1) Where is the urban forest?
- 2) If we want to make a record of the trees at our site, what kinds of information should we include?
- 3) What are some of the reasons why we would choose not to have trees here?
- 4) **Define:** urban forest, tree inventory, quadrant, circumference, diameter at breast height (DBH), and map.

Doing the Activity

Part A: Taking Inventory

- 1) Explain to students that they are going to conduct a tree inventory and later create a picture or a map of their area. Before students can make plans to monitor and improve their local urban environment, they should know what exists.
- 2) Assign students into one of the four teams to investigate each of the four quadrants.
- 3) Each team should fill out a data sheet which asks the following: tree name, circumference, height, and location.

Tree Name: Use a tree identification guide that also has exotic species to determine tree names. Match the actual tree's leaves, bark, flowers, or fruits to the one you find in the book. For more guidance on how to identify a tree, refer to the *Name that Tree* Activity #68 in PreK-8 PLT Activity Guide. For more information on trees in Florida check out the School of Forest Resources and

Conservation at University of Florida Web site: www.sfrc.ufl.edu/4h.

Height: Measure your shadow then your tree's shadow. Substitute and solve the following equation to find the height of your tree.

$$\frac{\text{Height of Tree}}{\text{Tree's Shadow}} = \frac{\text{Your Height}}{\text{Your Shadow}}$$

For more guidance on how to find the height of a tree, refer to the *How Big is Your Tree?* Activity #68 in PreK-8 PLT Activity Guide.

Diameter at Breast Height (DBH): To determine the DBH, measure around a tree at 4.5 feet above the ground to get the circumference then divide by 3.14 or *Pi*. Remember Circumference does not equal the Diameter.

$$\text{DBH} = \frac{\text{Circumference}}{3.14}$$

Example: If the tree circumference is 25 inches, divide this number by 3.14; DBH = 7.96 or about 8 inches.

Combine Your Results and Make a Class Bar Graph

- 1) What is the most common tree on your site?
- 2) Name 3 common trees in your area. How many of each do you have?
- 3) Graph tree height by number of individuals.
- 4) Graph tree DBH by number of individuals.

Part B: Mapping

The educator should show students a local paper map of their area or print one from one of the following Web sites. Point out a few characteristics that can help students read a map such as the use of symbols, scale, legend, north arrow, and the relative location of features.

- 1) Explain to students that maps are a bird's eye view of an area. Have students practice drawing trees, bushes, and buildings from this view.
- 2) Group students into several teams. Each team will use the following criteria to determine the quality of their map.

Good title: Short and descriptive

Effective use of symbols: Objects such as trees are well represented

Neat legend: It describes symbols well

Proper scale: Size and distance of objects are relative

Coordinates: The direction North is represented

Location of features: Group agrees with the location of features

3) Ask students what they remember about their study site and ask them to list both vegetation and human structures. This may include: trees, shrubs, trails, grassy areas, benches, fences, buildings, parking lots, playgrounds, paved pathways, electric wires, water hydrants, sidewalks, and storm water drains.

4) If the study site is a schoolyard, the educator should attain a base map of the school grounds by asking the school maintenance department or planning board. Using a separate piece of paper each team should trace the scale and the property line, and identify features such as buildings, bleachers, streets, pathways, fences, hydrants, telephone poles, and storm drains. If students are not provided with a base map these features should be drawn to the best of their ability.

5) Lay out a 50-foot measuring tape on the ground. Ask students to walk along this tape at a regular pace while noticing the distance of each step. If students know their walking pace they can use this skill to help them determine approximate distances between objects outside. If the site is large, they can use their pace to measure the distance between objects.

6) Teach students to use a compass to measure the degree bearing from one object to another. When making the map they can use a protractor to space these objects on paper.

7) Students should go to their study site and map the location of plants and built objects on graph paper and later transfer this information on a larger piece of paper, preferably graph paper. The map and compass section of the 4-H Forest Ecology contest has helpful information for teaching students how to use a compass and pace (www.sfrc.ufl.edu/4h).

Post-Activity Questions

- 1) What can you do with a map that is clear and accurate?
- 2) Were any trees in your site smaller than others? Why?
- 3) Which trees are consistently the tallest with the largest DBH?
- 4) Which type of tree is the most common?
- 5) How are trees used on this site?

Assessment

- Have students write down the most common tree at their site. Each student should be able to name one tree, its height, and location.
- Collect completed data sheets and maps to determine if students accurately described known trees and calculated tree height and DBH correctly.
- Have students identify two differences between two different tree species.

Enrichment

Have students use a digital camera to take photos of their site. Allow time for teams to research information about trees in their study site and have them do group presentations with visual aids. An alternative is to have the class create a brochure or booklet about the entire study site for other students to use.

Related PLT Activities

How Big is Your Tree? # 67

Name that Tree #68

Looking at Leaves #64

References

Wolowicz, R.S and M. Gera, 2000. Tree inventory and systematic management. In: Kuser, John E., comp., ed. Handbook of Urban and Community Forestry in the Northeast. New York, NY: Kluwer Academic/Plenum Publishers: 95-106.

Mapping Resources

National Geographic: Map Machine United States Geological Survey Education Resource: Map lessons http://interactive2.usgs.gov/learningweb/teachers/lesson_plans.htm

Atlas, World theme maps, Street maps, <http://plasma.nationalgeographic.com/mapmachine>

United States Department of Education Office of Education Research and Improvement. Helping your child learn geography <http://www.ed.gov/pubs/parents/Geography/index.html>

Florida 4-H Forest Ecology Contest Web site www.sfrc.ufl.edu/4h

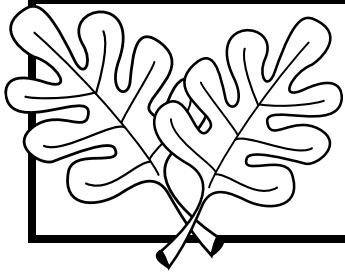

Percent Canopy Cover

New activity B

Goal 1: Urban Forest Ecosystem
Concept: Mapping and Exploring

Overview

A tree's canopy can provide many environmental, social, and economic benefits to a community. These benefits may include improved air and water quality, habitat for wildlife, reduced energy costs, and increased property values. In this activity, students will determine the overall canopy cover of their study site.

Objectives

Students will be able to 1) measure percent canopy cover; and 2) state how canopy cover influences the environment.

Materials

One 150 foot tape measurer.

Group set: densiometer, clipboard with paper, 5 metal hangers, tape, and 5 sheets of paper.

Each group will make 1 Densiometer.

Densiometer: 12-inches of string, PVC pipe or cardboard roll, adhesive tape, metal nut or washer, and scissors.

Background

The more canopy cover in an area, the greater the urban forest benefits the local community may receive. Trees, especially those with large leaf-surface areas, absorb and trap airborne dirt and chemical particles, and pollutants such as nitrogen oxide, sulfur dioxide, carbon monoxide, and ozone. Trees can improve water quality by reducing storm water runoff and soil erosion. A tree's canopy can provide space, food, and shelter for wildlife. Attractive, treed neighborhoods and landscapes can also foster a sense of community and belonging that can give people a sense of pride in their neighborhood.

Grade Level: 3 – 8

Time Consideration: 4 hours

Subject Area: Science and Math

Skills: Observing, Evaluating, and Measuring

Relevant Standards:

SC.D.2.2, SC.D.2.3 – The student understands the need for protection of the natural systems on Earth

SC.D.2.2, SC.D.2.3 – The student describes patterns of structure and function in living things

MA.A.4.2, MA.A.4.3 – The student uses estimation in problem solving

MA.B.1.2, MA.B.1.3 – The student measures quantities in the real world and uses the measures to solve problems

MA.B.3.2, MA.B.3.3 – The student estimates measurements in real-world problem situations

One way to measure the degree to which an urban forest can influence an area is by measuring tree canopy cover. The amount of tree canopy in an area is related to its ability to provide environmental, social, and economic benefits.

Getting Ready

1) We recommend students use the same site they had previously inventoried and mapped in the *Taking Inventory and Mapping* activity or mark out an area of 100 feet by 100 feet. A smaller area such as 50 feet by 50 feet can be used if necessary. The educator should divide the site into 4 equal quadrants to be studied.

2) Make a flag by unwinding a metal hanger then tape a piece of paper to one end. For each quadrant, place 1 flag at each corner of the study area and in the middle. If the study area is 100 feet by 100 feet, then each quadrant is 50 feet by 50 feet, with a diagonal approximately 70 feet. Along this diagonal, students will use a densiometer to take a canopy measurement every three feet. The center of this diagonal should be marked with a flag.

How to make a Densiometer

- 1) Select either cardboard toilet paper tube or PVC pipe.
- 2) Cut a 12-inch long string into three equal 4-inch pieces.
- 3) Thread the first 4-inch string through a metal nut or washer. Tape the ends of this string across one end of PVC pipe or cardboard roll. The washer should hang in the center, 1-inch below the tube.
- 4) Tape the other two 4-inch strings to the other end of the tube so they make an **X** at the end of the tube. Make sure both strings bisect the middle of the opening. Secure all the ends of string to the tube.
- 5) Check alignment of densiometer by looking up through the tube, holding it arm's length vertically straight above your head. The washer or metal nut should be on the bottom. As you look up through the densiometer the metal washer should align with the center of the **X**. Ask another student whether you are holding it vertically.

Practice walking at a three foot pace

1) Lay a measuring tape on the floor in a hallway. Ask each student to walk along the measuring tape and notice their pace. Allow each student to become accustomed to walking at a 3-foot pace. A pace is 2 steps, or every time one foot hits the ground.

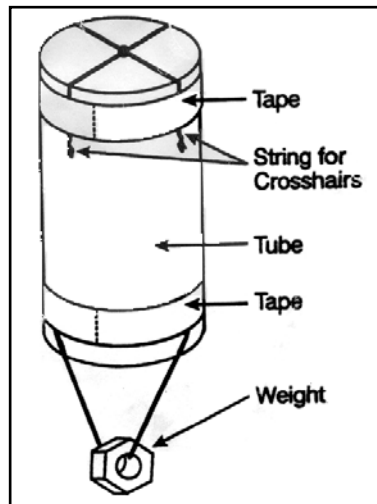

2) If each quadrant is 50 feet by 50 feet the diagonal is approximately 70 feet. If a measurement is taken every three feet, the densiometer reader and recorder will take 23 measurements along the diagonal.

Pre-Activity Questions

- 1) What benefits can a tree's canopy provide? Why is this important?
- 2) What percent of your site do you think is covered by the tree canopy? (25%, 50%, 75%, 100%)
- 3) Name a few natural and human factors that affect the presence of canopy cover.

Doing the Activity

- 1) Tell students they will be measuring the percent canopy of their study site. They will break up into groups that will measure the same site to then compare measurements.
- 2) Assign students into one of four teams and appoint the following roles: data recorder, densiometer reader, two flag people, and three densiometer builders.
- 3) When outdoors at the study site, go over your study boundaries. Students will take measurements in their assigned quadrant.
- 4) Have each group's densiometer builders make a densiometer. At the same time, the densiometer reader can measure their walking pace inside their assigned quadrant.
- 5) The densiometer reader should walk along their study area diagonal taking a canopy measurement every 3 feet. Use the flag in the middle of the site to guide where to walk. The recorder will record the data. The flag people will stand at either end of the diagonal to ensure densiometer reader is walking in a straight line.
- 6) Measurements are made by looking up through the bottom of the densiometer at the canopy above. Make sure the densiometer is held at arm's length above the reader's head.

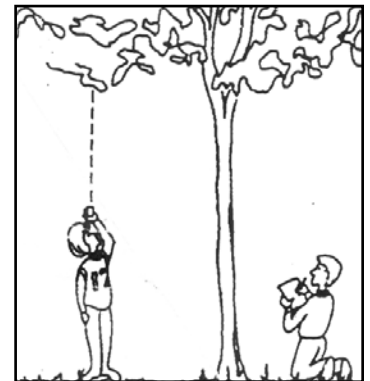
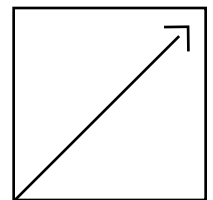

The metal nut or washer should be lined up with the center of the **X**.

7) If any part of the canopy is visible through the densiometer, record a (+); if none exists, record a (-).

8) Add the number of canopy (+) observations. Divide this number by the sum of all (+) observations and (-) observations which should be 23 for a 70 feet diagonal. Multiply this number by 100 to get the percent of canopy cover at your study site. Substitute and solve using the equation below.

of (+) _____ = a
Sum of (+) and (-) _____ = b
a/b _____ = c
c x 100 _____ = d
d = Percent Canopy

9) If there is time, each group should repeat this activity but within another quadrant.
10) Ask groups to compare canopy measurements.

Post-Activity Questions

- 1) What kind of tree contributed most to the overall canopy?
- 2) To increase the amount of shade where would you plant a tree?
- 3) What kinds of benefits are your urban trees providing right now?

Assessment

- Check student calculations to assess their accuracy.
- Students should write a short paragraph that explains the relationship between canopy cover and potential benefits.

Enrichment

Look up the percent tree cover in your town or city from the USDA Forest Service Web site: State Urban Forest Data <http://www.fs.fed.us/ne/syracuse/Data/State/downloads/RPA/florida.PDF>

Have students write a “Letter to the Editor” describing the information found in the table and voicing their opinion as to whether or not their city has sufficient tree cover.

Originally from:

Dwyer, J.F., D.J. Nowak, M.H. Noble, and S.M. Sisinni. 2000. Assessing our Nation’s Urban Forests: Connecting People with Ecosystems in the 21st Century. USDA Forest Service Gen. Tech. Rep. PNW-460. 540p.

Related PLT Activities

Air Plants #28
Name that Tree #68
Looking at Leaves #64
How Big is Your Tree? #67

References

GLOBE: NASA, NSF Science Curriculum Biomass Protocol: www.globe.gov

Nowak, D.J. and J.F. Dwyer. 2000. Understanding the benefits and costs of urban forest ecosystems. In: Kuser, John E., comp., ed. Handbook of Urban and Community Forestry in the Northeast. New York, NY: Kluwer Academic/Plenum Publishers: 11-25.

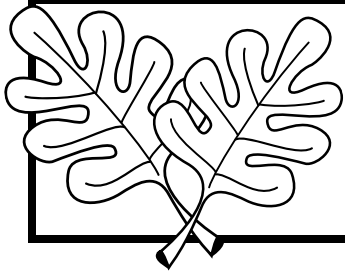

Modifications to PLT Activities to Enhance Exploring the Urban Forest Ecosystem

Habitat Pen Pals, Activity #7

Ask students to write letters from the perspectives of different urban animals instead of a natural ecosystem: pigeon, mockingbird, house sparrow, squirrel, mouse, cockroach, or raccoon.

The Forest of S.T. Shrew, Activity #8

Develop your own story from the perspective of an urban animal.

Charting Diversity, Activity #10

Substitute a sketch of a city in place of the desert.



Web of Life, Activity #45

Use urban plants and animals common to your area: pigeon, mockingbird, hawk, woodpecker, pine beetle, great blue heron, dog, cat, cockroach, mosquito, raccoon, mouse, crape myrtle, flowering dogwood, turfgrass, azalea, palm, cycad, ornamental kale, petunia, etc. If it is more difficult to make a web, ask students why? What food sources are missing?

Field, Forest, and Stream, Activity #48

Examine the physical factors that create microclimates in the urban environment. Look at the north and south sides of a large building, a swale that collects storm water, or a ball field.

Nothing Succeeds like Succession, Activity #80

Compare the concept of succession as it operates in a natural forest ecosystem to succession in an urban ecosystem. What changes are likely to happen or not happen and why? One factor that influences succession is wildfire. What is the effect of fire prevention and fire suppression in urban and rural environments?

Did You Notice?, Activity #95

Reflect on what rural places have become more built up. When and where did new roads and buildings appear? Compare city maps today with ones five years ago.



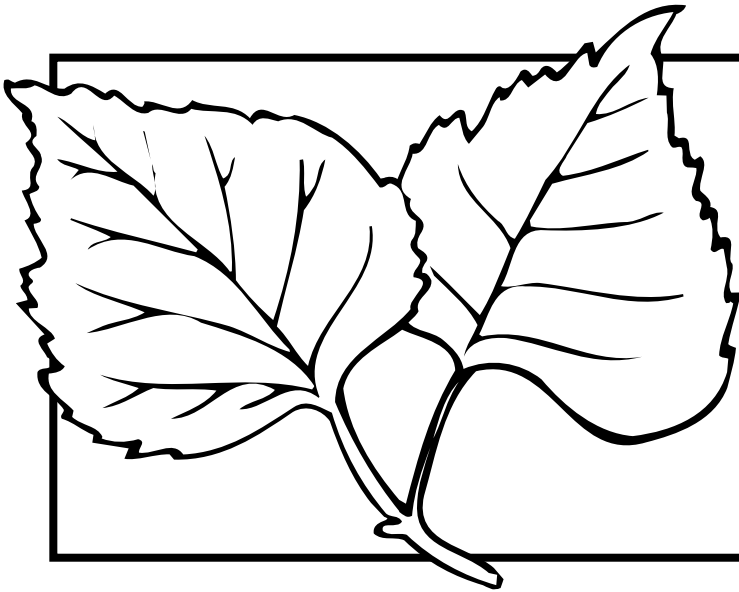

Section 3

Goal 2:

Increase youths' understanding of the benefits and costs of their urban forest

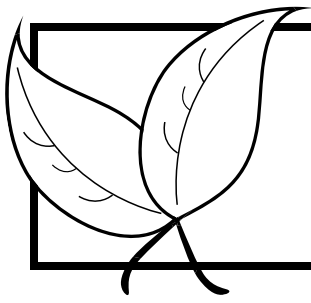

Water Wonders

PLT activity #44

Goal 2: Urban Forests' Benefits and Costs

Overview

An urban forest has the ability to mitigate the negative effects of urban development by reducing storm water runoff, lessening soil erosion, decreasing water pollution, and recharging aquifers. This exercise is an extension to the PLT Activity #44, *Water Wonders*. It uses three different models to demonstrate how land use can affect water quality and water supply in urban areas.

Objectives

Students will be able to 1) state how an urban forest, paved area, and compacted area respond after rainfall; and 2) explain how an urban forest can help communities reduce erosion, flooding, improve water quality, and recharge aquifers.

Materials

Each Group Should Have: Three 2-liter soda bottles, 1 empty plastic juice/milk jug, 3 pie pans, blocks or books, watch with second hand, 1 measuring cup, 1 tablespoon, soil, small section of grass, plastic wrap, food coloring, vegetable oil, colored sprinkles, and water. The teacher should have a box cutter.

Background

When it rains, leaves, branches, and stems intercept rainfall, reducing the speed water reaches the ground; this allows water to infiltrate underground more slowly. Trees and other vegetation have the ability to keep soil in place and absorb water. In fact, the roots of a moderately sized tree can absorb up to 400 gallons of water a day.¹ In addition, roots can absorb some chemical pollutants while soil can help filter out most particulates. Examples of pollution in urban areas include oil from cars, excess fertilizers from lawns, and litter.

Grade Level: 3 – 8

Time Considerations: 1–2 days

Subject Area: Science

Skills: Observing, Measuring, Predicting, Comparing, Contrasting, Evaluating, Analyzing, and Concluding

Relevant Standards:

SC.D.2.2, SC.D.2.3 – The student understands the need for protection of the natural systems on Earth

SC.G.1.2, SC.G.1.3 – The student understands the competitive interdependent cyclic nature of living things in the environment

SC.H.1.2, SC.H.1.3 – The student uses scientific processes and habits of mind to solve problems

If rain falls on impervious surfaces such as a street or parking lot, it will run quickly along the surface and pick up chemical and particulate pollution. Fast moving water is less able to soak into the ground and has the potential to cause flooding.

If rain were to fall on bare soil, that water could wash away a variety of loose materials and chemicals. This could cause soil erosion and sedimentation problems in streams, rivers, or storm drains. A 1996 study by the American Forests found that Fort Lauderdale's urban forest reduced the volume of storm water by as much as 18%. If some of that water were filtered through the urban forest it could recharge underground aquifers. Thus, towns and cities that remove their trees and fill in their open space will need to construct and maintain a larger storm water drainage system to handle the increased runoff. Maintaining or increasing the urban forest can help communities be more cost effective by conserving water, reducing erosion and flooding, and decreasing chemical pollution which improves quality of water.

Getting Ready

1) In advance, collect enough 2-liter bottles so that each group of students can have 3 bottles. Then cut all of the bottles with a box cutter to make a hole along their lengths.



2) Make a watering can for each group by puncturing small holes in the cap of a plastic jug.



Pre-Activity Questions

- 1) How can water become polluted in urban areas?
- 2) How can trees and other vegetation improve water quality?
- 3) **Define:** aquifer, erosion, impervious surface, pollutant, runoff, and watershed.

Doing the Activity

- 1) Group students into teams. Each team member should be assigned a role: model builder, timer, recorder, or pan holder.
- 2) Give each team three pre-cut 2-liter bottles and ask them to prepare the following models: Urban Forest, Paved Area, and Compacted Soil Area.

Urban Forest Model

Place 1 cup of soil in bottle. Dig up a small section of grass from the study site and place it in the bottle on the soil.



Paved Area Model

Place 2 cups of soil in bottle. Cover with 4 layers of plastic wrap. Tuck wrap around edges inside the bottle.



Compacted Soil Area Model

Place 2 cups of soil in the bottle. Press down with hands.



For best results, allow all models to sit in sun for 1 day which allows soil to dry evenly.

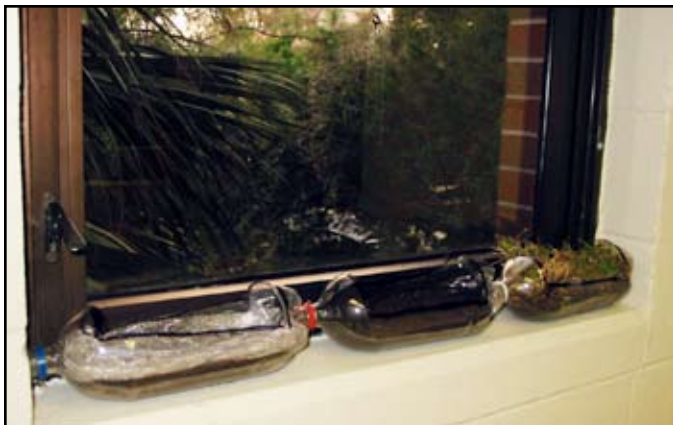

3) While keeping model level add the following pollutants:

- a) 1 tablespoon of colored sprinkles to represent litter.
- b) 2 drops of food coloring or quarter of a teaspoon to represent nitrogen and phosphates found in most fertilizers.
- c) 1 tablespoon vegetable oil to represent motor oil.



4) Predict what might happen when “rain” falls on each model using the data sheet.

5) Have groups prop up one model at a time 30 degrees or three thumbs high with a book or wood block. Place an empty pie pan at the open end of the model to catch runoff. The timer and recorder should get ready. One person should hold the pie pan.



6) Add 2 cups of water into watering can.

7) **SLOWLY** sprinkle 2 cups of water to represent rain on model for at least **ONE MINUTE**.



8) Immediately note the time in seconds when runoff starts to enter the empty pie pan. After sprinkling all two cups of water into the model students should observe the following using the data sheet as a guide: color of water and presence of oil, soil, and sprinkles in the pie pan.

9) Pour runoff from the pie pan into a measuring cup, measure its volume, and record it on the data sheet.

10) Repeat steps 3-9 for the other models.

11) After all of the models have been tested ask student groups to analyze their results and draw their own conclusions.

Post-Activity Questions

1) What happened in each model? Did it match your prediction?

2) In which model would groundwater recharge be best?

3) In which model would soil erosion be greatest?

4) Which model reduces water pollution the most?

5) How does an urban forest improve the quality of water, reduce runoff, lessen soil erosion, and recharge aquifers?

Assessment

Ask students to write a paragraph explaining how trees can improve water quality, reduce runoff, recharge aquifers, and cost cities less money.

Enrichment

The next time it rains students should observe how water moves across their study site. Ask students to point out where water soaks into the ground and where it runs into storm drains. Then discuss as a group how vegetation can change the flow of water running across their site.

Related PLT Activities

Every Drop Counts #38

Improve Your Place #96

Endnotes

¹American Forests. Urban Ecological Analysis of Dade County: Executive Summary, April 1996, For Urban Ecosystem Analysis Reports in U.S.

Metropolitan Areas

<http://www.americanforests.org/resources/rea>

Urban Forest Extension – Water Wonders: Data Sheet

What do you predict will happen when water falls on each model?

Urban Forest:

Paved Area:

Compacted Soil Area:

What did you observe?	Urban Forest	Paved Area	Compacted Soil
When did runoff start flowing into the pan? (measured in seconds)			
What color is the water in the pan?			
Do you see soil, sprinkles, or oil in the pan?			
Measure the water in the pan. Is it the same amount as when you started?			
How has the model changed?			

What are the variables in this experiment?

How did you control those variables?

How does replicating an experiment improve a conclusion?

Make a chart or graph of your results. Do you see any patterns or trends?

Did your result support your initial hypothesis?

If these three different models demonstrate how land use can affect water quality and water supply in urban areas, what would you conclude?

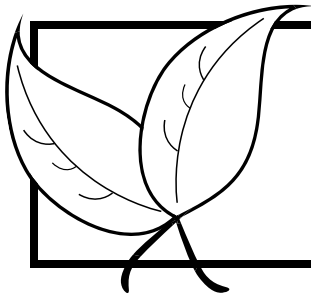

Urban Air Improvement

New activity C

Goal 2: Urban Forests' Benefits and Costs

Overview

Trees and other vegetation can mitigate the negative effects of urban development by absorbing airborne pollutants thereby improving the quality of the air in urban areas. In this activity, students will detect particulate pollution around their site.

Objectives

Students will be able to **1)** explain why projector sheets have different amounts of particulates by considering their location; **2)** name several sources of air pollution; and **3)** state how an urban forest contributes to cleaner air.

Materials

Clear overhead projector sheets, graph paper, petroleum jelly, flat 4-foot stick, clear packing tape, stapler, rubber mallet, and hand-lenses.

Grade Level: 3 – 5

Time Considerations: 3-5 days

Subject Area: Science, Math

Skills: Observing, Evaluating, Analyzing, Comparing, Contrasting, Measuring, Calculating, and Concluding

Relevant Standards:

SC.D.2.2 – The student understands the need for protection of natural systems on Earth

SC.H.1.2 – The student uses scientific method and habits of mind to solve problems

MA.A.4.2 – The student uses estimation and problem solving and computation

Background

The health and the well-being of our environment is affected by the air that surrounds us. A tree's ability to reduce airborne pollution is an example of one of the benefits it provides to urban communities.

Trees can remove pollutants by intercepting airborne particulates such as dust, dirt, and soot. Although some particles can be absorbed into a tree, most are intercepted and retained on the surfaces of trees and other urban vegetation. In urban areas, a major source of particulates come from vehicle exhaust. However, not all particulate matter is human-made. Some comes from natural sources such as pollen or volcanic eruptions.

The ways an urban forest can be managed to help improve air quality include: increase the number of healthy trees and maximize canopy cover; plant trees in energy conserving locations to reduce cooling and heating cost, thereby decreasing emissions from power plants; plant trees in polluted or in heavily populated areas; and choose trees that have needles or leaves throughout the year, which can potentially remove particulate matter year round. One of the best ways to affect air pollution is to sustain large healthy trees.¹

Getting Ready

- 1) The educator should look for heavily polluted areas such as bus stops or areas with vehicle traffic (e.g., parking lots).
- 2) Talk to people such as groundskeepers at your site about this experiment. The more you can communicate to anyone who will be using your study site the less others may tamper with your student's samples. You might want to put up a sign "Student Experiments – Please Do Not Touch – Thank You."

Pre-Activity Questions

- 1) What is in the air? Do you think there is anything in the air you can see?
- 2) When air is hazy what's in it?
- 3) Where do you think we can detect the most particulates?
- 4) How does weather affect particulate distribution?
- 5) **Define:** particulate, evergreen, and pollutant.

Doing the Activity

- 1) Explain to students that they will try to capture particulates from the air.
- 2) Hypothesize about where excessive particulates are located.
- 3) Group students into teams. Distribute two projector sheets for each student team.
- 4) Tell students to put their projection sheets about 3 feet above the ground near a bus stop or along a busy road and inside a dense urban forest.
- 5) Make a particulate-catching instrument by stapling the projector sheet to a wide, flat stick. It will be pounded into the ground with a rubber mallet. Smear all projection sheets with a thin layer of petroleum jelly.
- 6) After 3-5 days collect the projector sheets.
- 7) Place projector sheet over a piece of graph paper. Ask each group to count the number of squares that have particulate matter. You may wish to use a hand-lens.
- 8) Have students compare results between roadside and forest locations.

Post-Activity Questions

- 1) Which places had the most particulates? Why?
- 2) Which places had the least particulates? Why?
- 3) What do you think the particulates are?
- 4) Do all the particles look the same?
- 5) Where do you think the particles come from?
- 6) Do particles vary by location?
- 7) Since evergreen trees do not lose their leaves when seasons change, how would this affect the urban forest's ability to improve air quality?
- 8) Examine the samples from bus stop or highly trafficked area. Ask students how long and how many times they stand in these areas a week.
- 9) How could the quality of air affect your health?
- 10) How do trees and bushes influence air quality?

Assessment

Have students write a paragraph that describes how an urban forest influences air quality.

Related PLT Activities

Pollution Search # 36

Air Plants # 28

In the Driver's Seat # 85

Waste Watchers # 73

Endnotes

¹McPherson, E.G. and D.J. Nowak. 1993. Value of urban greenspace for air quality improvement: Lincoln Park, Chicago. *Arborist News* 2(6): 30-32.

References

Nowak, D.J. 2000. Impact of urban forest management on air pollution and greenhouse gases. In: Proceedings of the Society of American Foresters 1999 National Convention; 11-15; Portland, OR. SAF Publ. 00-1. Bethesda, MD: Society of American Foresters: 143-148.

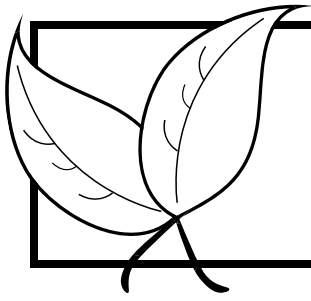

Tree Shadows

New activity D

Goal 2: Urban Forests' Benefits and Costs

Overview

A tree's canopy has the ability to mitigate the negative effects of urban development by cooling the environment it shades thereby potentially lessening urban heat island effect and lessening the need for air conditioning use. In this exercise students will make comparisons of the size and location areas shaded by individual trees at their site.

Objectives

Students will be able to 1) identify where a tree casts a shadow; 2) identify trees with large and small shadows; 3) describe the urban heat-island effect; and 4) explain how trees and other vegetation can help cool buildings, reduce air conditioning costs, and reduce air pollution.

Materials

2 air thermometers, 2 wire hangers, string, and scissors.

Group set: measuring tape, markers, tree identification guides, and clear overhead projection sheets.

Grade Level: 6 – 8

Time Considerations: Several different times in a day, optionally at different times during the year

Subject Area: Science, Math, Social Studies

Skills: Observing, Evaluating, Analyzing, Comparing, Contrasting, Measuring, and Concluding

Relevant Standards:

SC.G.2.3 – The student knows the consequences of using limited natural resources

MA.C.1.3 – The student describes, draws, identifies and analyzes two and three dimensional shapes

SS.B.1.3 – The student understands the world in spatial terms

Background

One way to measure the degree to which an urban forest can influence an area is by measuring tree shadows. It is often cooler under the shade of a tree's canopy than in direct sunlight. Urban areas that have more pavement and buildings to capture heat are usually warmer than rural areas. In fact, cities can be 2-10 degrees warmer than surrounding rural areas because buildings and pavement are made of materials that retain heat. When a building's surface is heated by the sun, heat is radiated into the surrounding air. In rural areas where there are only a few buildings, the radiated heat does not affect air temperature. In cities, because there are a lot of buildings and pavement, the radiated heat makes cities warmer than rural areas. The greatest difference in temperature between a city and its surrounding rural area can be felt in the early evening after a day of sunshine. This phenomenon is called the urban heat island effect.

Trees can reduce urban heat island effect by shading. A tree does this by blocking and reflecting heat from the sun. A tree's ability to shade buildings can also lessen the need for air conditioning use. As the demand for air conditioning use decreases, less power is needed which may lower power plant emissions while decreasing money spent by consumers.

A 1996 study sponsored by the American Forests found that over 90 percent of the homes in Dade County, Florida, have air conditioners. In fact, half of all residential energy use was dedicated to powering them. This study estimates that one mature tree in the right location near each home could save Dade County residents over \$14.4 million a year in reduced energy bills.¹

Getting Ready

1) We recommend students use the same site they had previously inventoried and mapped in the *Taking Inventory and Mapping* activity. If a map has not been created, the educator should draw one for this activity on a 8½" x 11" sheet of paper. This map can be used by the educator to visually show students their study site and it will be overlaid with several clear overhead projection sheets.

2) The educator should visit the study site to determine which trees have the biggest and smallest canopies and thus the biggest and smallest shaded area. For example, note where trees with small shadows are located such as palms and trees with large shadows are located such as live oak. It will be easier to identify isolated trees whose shadow is easily discerned.

Pre-Activity Questions

- 1) How do trees and other vegetation influence air temperature?
- 2) How much of your site do you predict is shaded by trees?
- 3) How does the time of day affect tree shadows?
- 4) How does the time of year affect tree shadows, winter versus summer?
- 4) **Define:** ambient air temperature, canopy, and urban heat island effect.

Doing the Activity

- 1) Explain to students that they will estimate size of the area shaded by a tree; however, the size and shape of a tree's shadow is influenced by the sun's direction in the sky and the shape of the canopy.
- 2) When outside, the educator should bring students to a tree with the largest canopy thus the largest ability to shade. Gather the group in the shade and ask them to compare the temperature to the area outside of the shade. What do they estimate the difference is in degrees? Record their predictions. Repeat this with the tree with the smallest canopy. Assign two students to take temperature readings in each tree's shade and outside the shade in the sun. Leave one thermometer in the sun and the other in the shade for the same amount of time, about 5 minutes. Record the temperature readings.

3) Explain that each team will be measuring the area shaded by several trees in their quadrant. You may wish to demonstrate how this can be accomplished before they move to their tree.

- a) To measure the area being shaded, students will measure the shadow of the canopy on the ground. Each team will measure the canopy portion of the tree and not its trunk. Each team will measure the longest part of a tree's shadow with a tape measurer and then measure the longest distance perpendicular to the first measurement. If we assume the shadow represents a circle we can calculate its area. Average the two distances to get the diameter and then divide by 2. This value will represent the radius of a circle whose area equals πr^2 . For older students, calculate both the longest and shortest sides of the elliptical shade and calculate an approximate size.

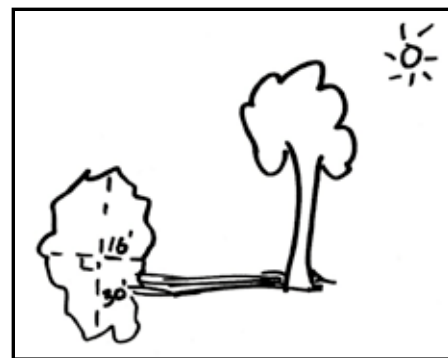

$$30 + 16 = 46 \div 2 = 23 = \text{diameter}$$
$$23 \div 2 = 11.5 \text{ radius}$$
$$3.14 \times (11.5)^2 = \text{area}$$

- b) Students should also record their tree's characteristics, common name, and what it shades (parking lots, buildings, walkways). Observe and record cloud conditions at the time of observation.

4) When the data have been collected, each team should organize their data to report to their peers. Encourage students to make bar graphs of their tree(s) and the size of its shade. Students should draw their shaded area on a clear projection sheet that will be placed on top of the class site map. The two students taking temperature readings should report to the class the temperature recorded for each tree. Compare them to the class predictions recorded earlier. Have each team report on their

findings. The finished shade map will be used in a discussion on how trees can provide shade and where.

5) Optional: It is ideal to repeat this exercise at different times of the day and at different seasons throughout the year.

Post-Activity Questions

- 1) Which tree provided the largest shadow?
- 2) Which tree provided the smallest shadow?
- 3) Did any of the trees shade a parking area or pavement? Why would this be beneficial?
- 4) Did any of the trees shade a building? How could this be beneficial?
- 5) If we use air conditioners less, how could this affect the emissions from power plants and the cost for air conditioning?
- 6) How do trees influence urban heat island effect?

Assessment

Ask students to write or explain the relationship between shading a building and air conditioning use, amount of emissions, and the costs for a consumer.

Enrichment

Survey the school or nearby community building for ways it could benefit from additional trees and

plants. Enlist the help of a landscaper to create an urban landscape plan.

Related PLT Activities

Air Plants # 28

Waste Watchers #73

Endnotes

¹American Forests. Urban Ecological Analysis of Dade County: Executive Summary, April 1996, For Urban Ecosystem Analysis Reports in U.S. Metropolitan Areas
<http://www.americanforests.org/resources/rea>

References

Heisler, G.M. and D.R. DeWalle. 1984. Plantings that save energy. *American Forests* 90(9): 13-16.

McPherson, E.G. and R.A. Rowntree. 1993. Energy conservation potential of urban tree planting. *Journal of Arboriculture* 19(6): 321-331.

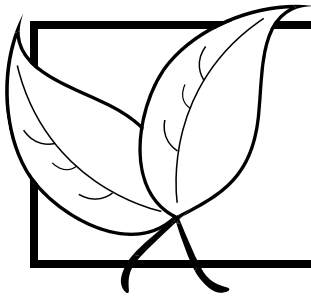

Investigating a Livable Community

New activity E

Goal 2: Urban Forests' Benefits and Costs

Overview

The presence or absence of trees and other plants can influence how we feel, think, and act. In this exercise, students will be social scientists whose goal is to determine if trees and other vegetation influence landscape preferences. Students will conduct this investigation using surveys and their findings will prompt discussion about how urban forests provide social and psychological benefits.

Objectives

Students will be able to **1)** survey an audience and tally results; **2)** compare and contrast results from different people; and **3)** state one psychological or social benefit of an urban forest.

Materials

7 copies of pictures and 70 copies of surveys, plus one copy for each student.

Grade Level: 6 – 8

Time Considerations: 2-5 days

Subject Areas: Social Studies, Math

Skills: Identifying Attributes, Counting, Organizing, Making Charts and Graphs, Comparing, Contrasting, and Interpreting

Relevant Standards:

SS.B.2.3 – The student understands the interactions of people and the physical environment

MA.A.4.3 – The student uses estimation, problem solving, and computation skills

MA.E.1.3 – The student understands and uses the tools of data analysis for managing information

MA.E.2.3 – The student identifies patterns and makes predictions from an orderly display of data using concepts of probability and statistics

Background

People like trees and other plants for a variety of reasons. They affect our perception of the world in important social and psychological ways. They may help make where we live, work, learn, and play more enjoyable.

In this exercise, students will be social scientists exploring the psychological relationship between people and their environment. A social scientist uses the same kinds of skills that a biological scientist would when uncovering new information. They collect and organize data then interpret and construct an explanation and communicate that explanation to others.

We know that the presence of trees and other vegetation can affect our moods, attitude, and health. For some people, trees are symbolic. They represent hope, prosperity, life, and peace. This is why they are planted as living memorials for people or events. Having an appreciation for the beauty of plants can enable one to enjoy the beauty of a place. In general, if people experience a positive emotion due to trees and other plants, they may select places that have them. However, studies also show that highly vegetative areas that block a person's view can bring about feelings of fear or discomfort.

Research has shown that the presence of trees and vegetation can contribute a restorative effect thus making an urban area more livable.^{1,2} For example, when a person concentrates on something such as an exam or driving through the rain at night, he/she use *directed attention*. After an extended period of time, the ability to concentrate begins to fatigue. One way to renew and refresh this mental fatigue is to use *involuntary attention*. Involuntary attention is

effortless; we use it when we notice sights, smells, and sounds or when we do enjoyable things, such as walking in a park or gardening. When directed attention is restored, it is easier to pay attention and concentrate.

Life in an urban area can be rushed, noisy, hot, and crowded, leading to increased stress and anxiety. Constant stress can lead to chronic mental fatigue, which is sometimes a precursor to aggressive, violent behavior. It can also diminish a person's ability to cope when faced with a challenging situation.⁴

Research has shown that well-groomed, green common spaces increase the chance people will use them, which promotes community engagement. Studies have also shown when there are more people using outdoor spaces, there is less crime, littering, loitering, noise pollution, and property damage. In this way urban forest can lower neighborhood stress levels.^{3,4,5} Even having a view of nature from a hospital window has been related to shortened hospital stays and quicker recoveries.⁶ Other general studies indicate reducing stress can enhance a person's immunity, which can lead to better health.

The urban forest is alive and dynamic. Where there are trees and other plants, there will also be insects and other animals. These environments usually have a variety of things to touch, see, hear, smell, and sometimes taste. Being in a stimulating, interactive, vibrant surrounding may allow students to be more creative which may encourage imagination.⁷

In summary, having an urban forest can help to reduce stress and anxiety, improve health, and contribute to greater mental productivity. Nearby trees can help make a place more likeable, attractive, pleasant, and enjoyable. The urban forest can make us feel good which increases the psychological and social health of people.

Getting Ready

1) The educator should have students practice using the surveys in class. Make copies for each

student and show the pictures on a projector screen.

2) Make 70 copies of the survey and 7 copies of the pictures.

Pre-Activity Questions

1) On your way to school today did you notice the trees or other plants? Where were they? Do you think they influence how we feel, think, or act? How?

2) Some indoor areas such as office buildings, entry ways, and malls have plants and waterfalls. What might be the advantage of this type of interior decoration?

3) Do you think different people feel the same way that you do toward trees and well groomed green spaces? How can we prove this?

4) What instrument can a social scientist use to assess feelings and attitudes?

5) **Define:** psychological, social scientist, and survey.

Doing the Activity

1) Explain to the students that they will collect data to help answer the question, "Does the urban forest influence how we feel, think, or act?"

2) Divide students into 7 groups and assign each group one of seven age groups (≤ 10 , 11-20, 21-30, 31-40, 41-50, 50-60, and ≥ 61).

3) Explain to student groups that they will survey at least 10 people in their assigned age group.

4) To become comfortable with the survey and survey process, tell the class they will first practice using the survey. Pass out the surveys. Ask each student to survey one student next to him or her and then switch. Ask students to add the group **A** responses then add group **B** responses. Compare results as a class.

5) Ask students who they would choose to survey for this study. Recommend choosing neighbors, other kids at school, or their family members and make it mandatory that they conduct this survey as a group for safety reasons.

6) Pass out 10 surveys and 1 set of pictures to each group.

7) When each group has brought in their 10 surveys, ask the following questions:

- a) Look at the questions 1-3 on the survey. Research tells us that the urban forest helps people feel better and has a calming, relaxing effect. Which group pictures did most of your survey participants choose for these questions?
- b) Look at questions 4-6. Some people think the urban forest is a peaceful place and helps to restore focus to think. Did your results match this idea?
- c) Look at questions 7-9. Having an urban forest allows us to do different things. It might be a nice place to visit with friends or help you be more creative since there are more things to see, hear, smell, and touch. Did most of your results reflect this idea?

8) The educator should copy the class results sheet on a dry-erase or chalk board then tell students they will fill out one row that represent their specific age group.

9) Ask each group to add up their age group's data. They should separate the surveys into two piles – males and females. Then add all of the total **A** scores for all the male respondents, then all the **B** scores. Repeat for females.

10) One student from each group should fill in their observations on the master class chart. Encourage students to make charts and graphs with their results.

Post Activity Discussion

- 1) What were some of the most interesting findings in your study? Was there anything that surprised you?
- 2) Do you think people feel, think, or act differently if there is an urban forest? Do your results suggest this? Does any age group prefer less forested scenes? Why might this be?
- 3) What would change if you lived without trees and other vegetation?
- 4) Research suggests that an urban forest can help make a place more livable, with social and psychological benefits. What does that mean? How much is that worth to you personally?

Assessment

- Have students write a paragraph explaining the class results and their interpretation of why they think their group chose group **'A'** or group **'B'**.
- Ask students to name one social or psychological benefit an urban forest may provide.

Related PLT Activities

Poet-Tree #5

I'd Like to Visit a Place Where... #54

Endnotes

¹Taylor, F., F.E. Kuo, and W.C. Sullivan. 2002. Views of nature and self-discipline: Evidence from inner-city children. *Journal Environmental Psychology* Special Issue: Environment and Children 22: 49-63.

²Taylor, F., F.E. Kuo, and W.C. Sullivan 2001. Coping with ADD: The surprising connection to green play settings. *Environment and Behavior* 33(1) January: 54-77.

³Kuo, F.E. 2003. The role of arboriculture in a healthy social ecology. *Journal of Arboriculture* 29(3): 148-155.

⁴Kuo, F.E. 2001. Coping with poverty: Impacts of environment and attention in the inner city. *Environment and Behavior* 33(1): 5-34.

⁵Kuo, F.E. and W.C. Sullivan 2001. Aggression and violence in the inner city: Effects of environment via mental fatigue. *Environment and Behavior* 33(4): 543-571.

⁶Ulrich, R.S. 1984. View through a window may influence recovery from surgery. *Science* 224: 420-21.

Survey: Investigating a Livable Community

Thank you for participating in this survey. You will be choosing one picture from either column A or column B for each scenario. Each group of pictures represent where people live, work, learn, and play. Please complete the demographic questions at the bottom.

- | | | |
|---|---|---|
| 1) If you wanted to feel better, where would you rather be? | A | B |
| 2) If you were angry, which group of places would help you relax and calm down? | A | B |
| 3) If you had 10 minutes to take a break from a difficult task, where would you like to go? | A | B |
| 4) If you wanted to focus and think better, which group of settings would you choose? | A | B |
| 5) If you had to pick a place to read and study, which group of areas would you choose? | A | B |
| 6) Which set of pictures would you want outside of your window at school, work, or home? | A | B |
| 7) Which group of places would you spend more time enjoying with your friends? | A | B |
| 8) If you want to draw a picture or write a poem, which group of scenes helps you be more creative? | A | B |
| 9) In which group of places would you prefer to live, work, learn, and play? | A | B |

Total A=

Total B=

Gender: Male or Female

Age: 0-10 11-20 21-30 31-40 41-50 51-60 61+

Class Results: Investigating a Livable Community

The purpose of this study is to determine whether the urban forest could influence how we feel, think, and act and to discuss how trees and vegetation might contribute to the livability of an urban environment.

Directions: Educator should copy master class results on dry erase or chalkboard for the class. Each student group will separate their surveys by gender and tabulate their findings. One person from each group should input data in one of the rows on the board and create class bar graphs.

Master Class Results

Ages	Male Preferences		Female Preferences	
	A	B	A	B
0-10				
11-20				
21-30				
31-40				
41-50				
51-60				
61+				
Totals				

Example Graph

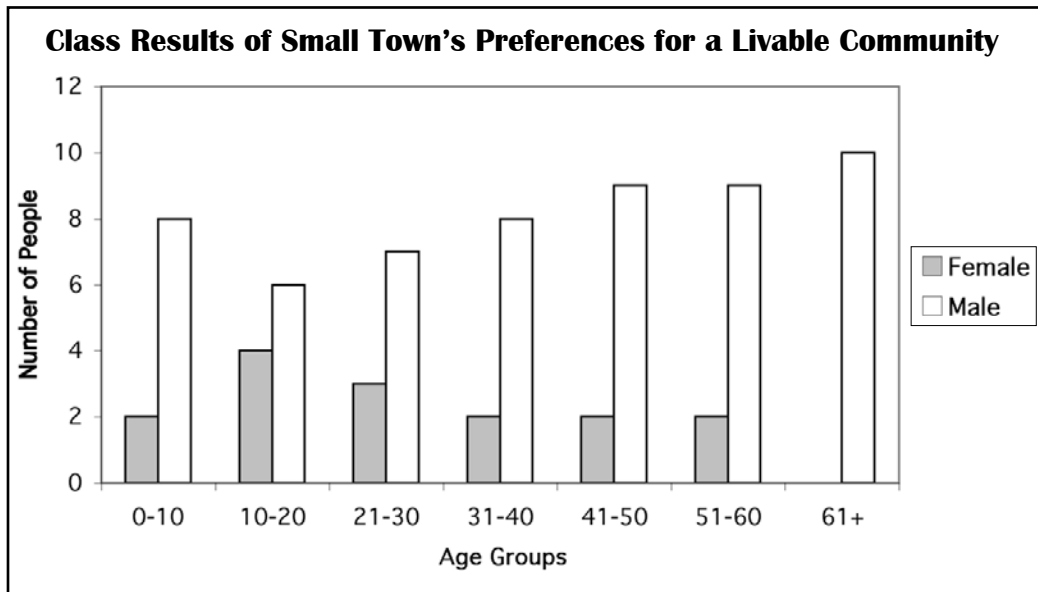

Pictures: Investigating a Livable Community

Group A

Group B



Live



Learn/Work



Play



Photos Courtesy of Gwen Ryskamp and Jennifer Seitz

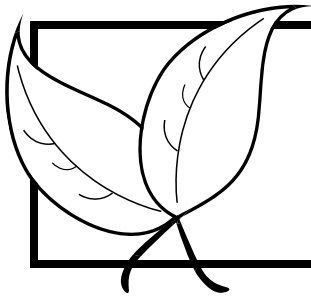

Weighing Costs and Benefits

New activity F

Goal 2: Urban Forests' Benefits and Costs

Overview

There are both benefits and costs of having an urban forest. In this activity, students will develop arguments about whether or not we should support an urban forest. Using one of the listed statements provided, students will research the advantages and disadvantages of an urban forest.

Objectives

Students will be able to 1) state the difference between an emotional and logical argument; and 2) describe one cost and one benefit of the urban forest.

Materials

Library/Internet research.

Grade Level: 6 – 8

Time Considerations: 2 days – 1 week

Subject Area: Language Arts, Science

Skills: Researching, Listening, Reflecting, and Questioning

Relevant Standards:

L.A.C.1.3 – The student uses listening strategies effectively

L.A.C.3.3 – The student uses speaking strategies effectively

L.A.D.2.3 – The student understands the power of language

SC.H.1.3 – The student uses scientific processes and habits of mind to solve problems

Background

There are many reasons why we should or should not include trees and other vegetation in our urban communities. The decision to include plants is often made by people who have logical or emotional assumptions in this regard. A logical argument will have clear, well-reasoned supporting evidence. An emotional argument will not have these characteristics; instead it may sound reactive, unproven, inconsistent, or sentimental.

In this activity, students will develop arguments that support whether we should have or not have an urban forest. This decision will be made by comparing explanations for either the advantages or disadvantages of an urban forest. After all the supporting evidence has been presented and weighed, students will vote on the group that has the most persuasive, reasonable, and logical case. Students can choose to debate this issue in several different types of mock forums: school planting project, neighborhood planting group, planning board meeting, or homeowners' association meeting.

This exercise tries to extend the limits of what we know about the urban forest by providing general statements. Students are asked to go to the library or use the Internet to research their statement, then use it in an argument to debate the future of their urban forest.

Getting Ready

Students are encouraged to create graphs, draw pictures, and bring in articles as supporting evidence for their reasoning. The educator's role is that of a facilitator and organizer of the debate.

Pre-Activity Questions

- 1) What are the characteristics of a good argument?
- 2) What is the difference between a logical argument and an emotional one?
- 3) **Define:** cost-benefit analysis.

Doing the Activity

- 1) The educator should group students into two teams.
- 2) A pair of students in each team should be given a statement to research. They will organize, embellish, and use this information as supporting evidence for their argument for or against having an urban forest.
- 3) Before the debate, allow each team to organize all of their arguments and prepare a presentation.
- 4) The educator should introduce the issue then allow each student pair to present its findings.
- 5) The educator should write key ideas on the board.
- 6) At the end of the debate, ask students to describe aspects of the most logical presentation and the most emotional presentation. Discuss what makes these strategies more compelling, reasonable, and persuasive.

Post-Activity Questions

- 1) Describe one good argument for or against having an urban forest.
- 2) What are some of the potential compromises that could allow both sides to reach an agreement? (For example, if someone believes an urban forest is an unsafe hiding place for illegal activity but wants trees and vegetation where they live, they may choose to plant tall trees and low lying vegetation that won't block the view).

Assessment

- Have students list the qualities of a logical argument, then write an example of one good argument for and against having an urban forest.
- Have students write a persuasive well-reasoned paragraph that explains why we should or should not have an urban forest.

Related PLT Activities

Viewpoints on the Line #19
We Can Work it Out #56

References

Northeastern Area State and Public Forestry: The Hazard Tree Web site
<http://www.na.fs.fed.us/spfo/hazard/>

Treelink: Twenty Nine Reasons for Planting Trees,
http://www.treelink.org/docs/29_reasons.phtml

Resources

Dwyer, J.F., E.G. McPherson, H.W. Schroeder, and R.A. Rowntree. 1992. Assessing the benefits and costs of the urban forest. *Journal of Arboriculture* 18(5): 227-234.

Nowak, D.J. and J.F. Dwyer. 2000. Understanding the benefits and costs of urban forest ecosystems. In: Kuser, John E., comp., ed. *Handbook of Urban and Community Forestry in the Northeast*. New York, NY: Kluwer Academic/Plenum Publishers: 11-25.

Supporting Statements: Disadvantages of an Urban Forest

- 1) It costs money to buy trees and maintain them.
- 2) Trees can be dangerous. Tree limbs can fall on houses, cars, and people.
- 3) Extensive planting of exotic tree species like Melaleuca have been known to decrease local water levels, increase fire risk, and change ecosystems thereby decreasing native biodiversity.
- 4) Uprooted trees and tree limbs may be broken during a hurricane, damaging roads, yards, houses, people, and cars.
- 5) Dead trees or snags look untidy.
- 6) Tree roots can grow very large and break up streets and sidewalks which cost a community money to repair.
- 7) If someone lost control of his/her car and hit a tree, he/she could die.
- 8) Trees falling on utility lines can knock out power and start fires.
- 9) People don't like raking leaves.
- 10) Trees bring insects and diseases.
- 11) There is absolutely no suitable space for a tree in the city.
- 12) Trees and other vegetation promote allergies from their pollen.
- 13) People don't want to be responsible for a tree if it falls down.
- 14) Dry leaves on rooftops and around homes can catch on fire and burn down whole neighborhoods.
- 15) Since property is expensive in urban areas, it becomes too costly to have trees and other vegetation.
- 16) An urban forest that blocks views provides a hiding space for criminals and illegal activity.

Supporting Statements: Advantages of an Urban Forest

- 1) The urban forest can help reduce storm water runoff.
- 2) Well-groomed common spaces in neighborhoods will be used more by people. This will increase the chance for neighborhood interaction and potential friendships to grow and decrease the chances of violent crime, loitering, littering, and property damage.
- 3) Trees can help reduce heating and cooling costs by providing shade and blocking wind.
- 4) Having trees and other plants around makes people feel better.
- 5) Plants improve the quality of air by taking carbon and other gases out of the air. Tree leaves can filter particulates from the air.
- 6) Dead trees or snags provide a place for wildlife to live.
- 7) If someone lost control of his/her car, a pedestrian could hide behind a tree saving her or his life.
- 8) Trees hold soil in place, preventing erosion during rainfall which helps waterways stay clean.
- 9) Trees offer protection from wind and act as a buffer from noise pollution.
- 10) Planting native trees may support native animals that depend on them.
- 11) Urban residents benefit from the serenity and healing effects of an urban forest.
- 12) Trees can make a neighborhood more beautiful and increase the property values.
- 13) People prefer to shop and work in places with well-groomed trees and vegetation.
- 14) A healthy urban forest may better withstand hurricanes and tropical storm winds.
- 15) An urban forest provides relief from the constant and repeated stress of hot, noisy, crowded urban spaces.
- 16) Urban forests can help mitigate the negative effects of urban development.

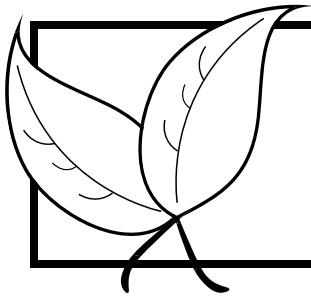

Modifications to PLT Activities to Enhance Learning about the Benefits and Costs of an Urban Forest

Viewpoints on the Line, Activity #19

Include statements about the urban forest: 1. It is expensive to plant and maintain an urban tree. 2. Urban forests can help save a city money. 3. The psychological benefits of an urban forest help make it possible for people to enjoy living there. 4. Falling limbs and broken power lines make urban trees too dangerous. 5. We should only plant non-invasive trees in the urban forest. 6. Cities should plant trees resistant to hurricanes.

Loving It Too Much, Activity #35

Compare and contrast the use of our national parks with the urban parks in your area. Consider all the reasons people go to parks, then write a plan that balances resource conservation with meeting people's needs.



In the Good Old Days, Activity #91

Look for ways urban and rural forests are portrayed by environmental figures through their writing. Modify the list of authors by adding people such as Frederick Law Olmstead who wrote about the urban forest.

A Look at Lifestyles, Activity #92

Analyze the difference between Native American and Pioneer lifestyle to today's urban and rural lifestyle. What is the difference in their daily lives? What is considered necessary for survival and what is a luxury?



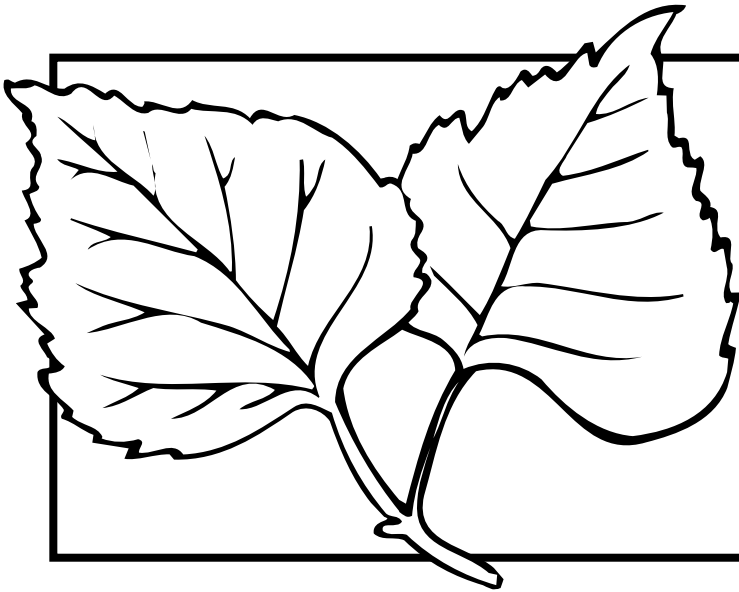

Section 3

Goal 3:

**Engage youth in opportunities
to monitor, maintain, and
enhance the urban forest**

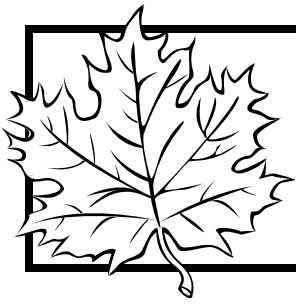

Trees in Trouble

PLT activity #77

Goal 3: Opportunities for Action

Concept: Forest Health

Overview

The urban forest has the potential to provide us with a great number of benefits, thereby lessening the negative effects of urban development. The ability of an urban forest to provide those benefits may depend on the health and vitality of individual trees. Using PLT Activity #77 *Trees in Trouble*, students will observe the health of trees by examining their trunk, roots, canopies, and location.

Objectives

Students will be able to **1)** observe and describe characteristics of tree health; **2)** compare and contrast different trees at their site to hypothesize about the overall health of their urban forest; **3)** evaluate the overall health of the urban forest for wind resistance; and **4)** make recommendations for wind-resistant trees.

Materials

Data sheets, clipboard, pencils, tree identification guide, tape measurer, and copies of *Tree-tective Trouble Guide* and *Reading Leaf Symptoms* pages 335-336 in the *PreK-8 PLT Activity Guide*.

Grade Level: 3 – 8

Time Consideration: 1 day

Subject Areas: Science

Skills: Observing, Measuring, Comparing, Contrasting, Analyzing, and Concluding

Relevant Standards:

SC.D.2.2, SC.D.2.3 – The student understands the need for protection of natural systems on Earth

SC.G.1.2, SC.G.1.3 – The student understands the competitive, interdependent, cyclic nature of living things in the environment

Background

Forest health is an indicator of environmental health. A healthy tree has access to adequate amounts of water, nutrients, sunlight, space, and oxygen in the soil. An unhealthy tree may be limited by one or more of these resources, or be damaged by natural and human factors. Unhealthy trees are also more susceptible to disease, insect damage, drought, flooding, poor soil conditions, wind damage, and competition than healthy trees. Urban trees have the added stress of soil compaction, pollution, restricted growing spaces, physical wounding from vandalism, vehicles, and construction equipment.

When a tree is injured, a natural process begins that results in covering the wound with bark and new wood. This is called wound closure or callusing over. The larger the wound, the longer it will take a tree to heal, increasing the chance of infection from diseases, fungi, and insects.

Trees can be severely damaged if cars, people, and heavy equipment damage their roots. Since the majority of a tree's roots can be found within the top few feet of soil, excessive soil compaction can impede root growth. This, in turn, can decrease the tree's ability to take up nutrients, oxygen, and water. A significant amount of damage can also occur when several roots are injured from pulling and digging.

Symptoms of nutritional deficiency, cold damage, drought, chemical exposure, insect damage, and disease often show up first in the leaves.

Use the *Reading Leaf Symptoms* on page 336 in PLT book as a diagnostic tool for determining the type of stress your local trees might be facing. Your local Cooperative Extension Office will also be able to provide you with information on the possible causes of tree stress. Unhealthy leaves can affect how a tree makes food.

Assessing the overall canopy is another important step in evaluating the health of a tree. Canopies are considered unhealthy when there are a large number of dead branches without leaves on the very top of a tree. This is called dieback.



Healthy tree canopy



Unhealthy tree canopy
with die-back

The location of human structures will also affect a tree's health. If a tree is next to new infrastructure, it is very likely that the roots were cut during construction. However, if the tree was planted after construction was completed the influence will be less. The location of a tree, its proximity to a structure, and knowing when that structure was built will aid in evaluating how well that tree will function in its urban environment.

By observing a tree's trunk, exposed roots, leaves, branches, canopy, and relationship to infrastructure, students can get an overall picture of how well a tree is doing. Combining this information with tree characteristics such as height and diameter and comparing it to similar trees provide evidence of how well a tree is growing.

Preventing problems is one of the best ways we can help a tree grow. By identifying these stresses and trying to minimize them we can contribute to the health of our urban forest. When the urban

forest is healthy, it will have a better ability to provide potential benefits to the community.

Part A: Tree Health

Pre-Activity Questions

- 1) Name several conditions that could damage a tree. (*disease, wounding, excess fertilizers, runoff, compacted soils, lack of nutrients, insects, location to human structures, and lack of sunlight*)
- 2) Name the parts of a tree that you can observe that will help you determine the health of your tree.
- 3) How do people impact the urban forest?
- 4) **Define:** infrastructure and die-back.

Doing the Activity

- 1) Make copies of *Tree-ective Trouble Guide* and *Reading Leaf Symptoms* on pages 335-336 in PLT book. Review the different types of tree damage students may observe around their study area.
- 2) Review the *Individual Tree Health Observation Sheet* with the class. Ask the students to develop a list of criteria to define each rating (good, fair, poor) for the roots, trunk, leaves, branches, and canopy.
- 3) If students finished the *Taking Inventory and Mapping Exercise*, assign them to the same study site. Otherwise, ask pairs of students to fill out one observation sheet per tree. The following information should be recorded for each tree:
 - a) **Tree Characteristics:** species, height, and DBH (diameter at 4.5 feet above ground)
 - b) **Tree Condition:** observations of the roots, trunk, leaves, branches, and canopy
 - c) **Location:** Is the tree near a side walk, under a telephone wire, near a dirt path, open field or new construction?
 - d) **Overall Rating of Tree Health:**
Good, Fair, Poor
- 4) Copy the *Class Analysis Sheet* on a large chalk or dry-erase board or project the chart on an overhead transparency. Have students add their individual findings to the class analysis sheet to get an overall picture of tree health for the entire site.

Post-Activity Questions for Part A

- 1) What type of damage, if any, was most common to the trees at your site? What may have caused the damage?
- 2) Are there locations where trees seem to be more damaged?
- 3) What could we do to promote urban tree health?
- 4) What is the general health of trees at this site?

Part B: Wind Resistance

Pre-Activity Questions

- 1) How does wind affect trees?
- 2) How do different wind speeds affect trees?
- 3) Why do you think that some species are more resistant to winds than others?
- 4) What tree would resist winds better: a young, vigorous tree or an old, large tree? Why?
- 5) What are the factors that contribute to tree loss or damage by winds?
- 6) **Define:** arborist, resistance, and susceptible

Doing the Activity

- 1) Make copies of the wind resistant lists on page 56-57 (please note the different lists for North, Central or South Florida tree species – students should use the most appropriate list for their location) and the wind resistance in the urban forest article for each student (page 55). After reading the article, have the students come up with a list of important factors that determine wind resistance in trees.
- 2) Assign students to the same study site they explored in Part A.

- 3) Have students find the observed trees in their study area on the wind resistant list and identify which trees have high, medium, or poor wind resistance. Use the individual tree health observation sheet used in Part A to assess potential problems in a high wind.

Post-Activity Questions for Part B

- 1) How does tree health relate to wind resistance?
- 2) How wind resistant is your urban forest?
- 3) What actions can one take to enhance the health of the urban forest?

Assessment

- Collect *Individual Tree Health Observation Sheets* to determine whether students have described tree health correctly.
- Have students list in a written paragraph the several factors that cause stress to an urban tree.
- Have students write a paragraph about what can be done to prevent wind damage next time a hurricane or tropical storm hits the urban forest.
- Ask students to write a creative story from the perspective of a tree that describes challenges to tree health. (For example “A Trip to the Tree Doctor” or “A Tree in a Hurricane”)

Related PLT Activities

Tree Factory #63
How Plants Grow #41

Individual Tree Health Observation Sheet

Names: _____ Date: _____

Season: _____

1) Tree Characteristics:

Species: _____ Height: _____ DBH: _____

2) Tree Condition:

Roots: Are the roots exposed, dug up, or damaged? _____

What do you think caused this problem? _____

Rate the overall condition of the roots you can see: Good Fair Poor

Trunk: Are any wounds visible on the trunk? Describe: _____

What do you think caused this problem? _____

Rate the overall condition of the trunk: Good Fair Poor

Leaves: Are many leaves eaten, discolored, or wilted? Describe: _____

What do you think caused this problem? _____

Rate the overall condition of the leaves: Good Fair Poor

Branches: Are there broken branches? Describe: _____

What do you think caused this problem? _____

Are there dead branches at the top of tree or canopy? Describe: _____

Rate the overall condition of the branches: Good Fair Poor

Canopy: Rate the overall condition of the canopy: Good Fair Poor

Structure within the dripline of a tree's canopy

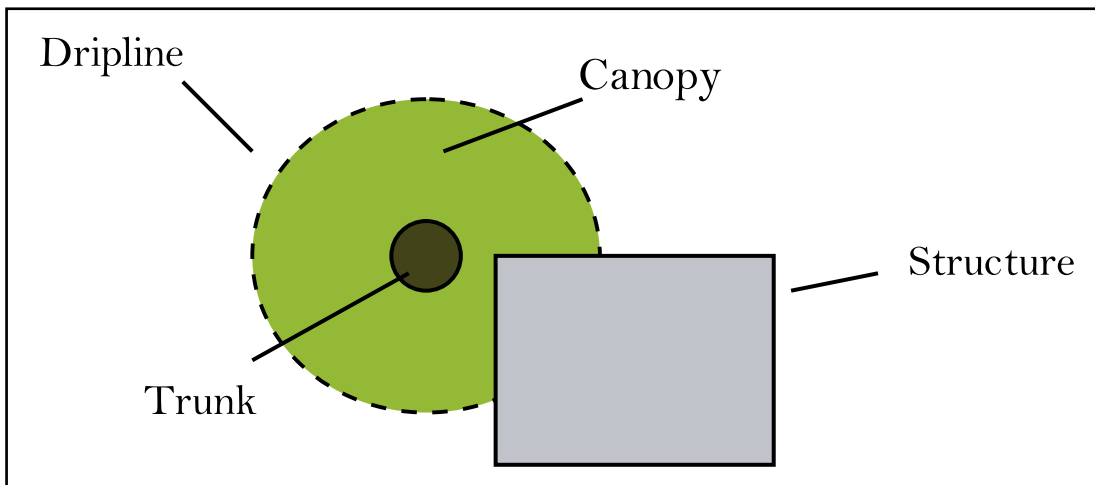

3) Location:

The things near a tree, like buildings, underground pipes, walkways, or roads can affect a tree's health. The edge of the canopy or dripline is considered the critical zone. It is where a tree gathers water, oxygen, and minerals. If a structure is built within the critical zone there is a chance the tree's roots were cut which can affect its health. However, if a tree was planted after construction the roots will grow in another direction. Therefore, it is helpful to know if a tree was planted before or after construction. You can determine this by asking grounds people or comparing the size of the tree to the age of the building.

Describe the location of the human elements around your tree (pavement, buildings, utility wires, underground structures, or parking lot)

Are you in the dripline?

4) **Overall Rating of Tree Health:** From the information you gathered about your tree, what is your assessment of this tree's health (Good, Fair, Poor) and why?

5) What could be done to improve the health of this tree if anything?

Class Analysis Sheet

Group same species together for analysis

A) Tree Species _____

Common Name

Description	Tree #	Tree #	Tree #
Height			
DBH			
Roots (Good, Fair, Poor)			
Trunk (Good, Fair, Poor)			
Leaves (Good, Fair, Poor)			
Canopy (Good, Fair, Poor)			
Branches (Good, Fair, Poor)			
Location			

B) Tree Species _____

Common Name

Description	Tree #	Tree #	Tree #
Height			
DBH			
Roots (Good, Fair, Poor)			
Trunk (Good, Fair, Poor)			
Leaves (Good, Fair, Poor)			
Canopy (Good, Fair, Poor)			
Branches (Good, Fair, Poor)			
Location			

Wind Resistance in the Urban Forest

Florida's urban forest is very diverse and provides many benefits to urban communities. Hurricanes and tropical storm winds, however, can cause major damage. Since the urban forest occurs where people live, it is very important to have a healthy urban forest to minimize property damage and human injuries from trees falling over during storms.

A healthy urban forest has a diversity of plant species that are both young and old. A healthy urban forest also has the right trees planted at the right places. For instance, a tree that is too big for the place where it was planted is more likely to fall during strong winds. Also, a tree's location in relation to infrastructure can affect its health. For example, construction activities within 20 feet of a tree can cause it to blow over more than ten years later.

Likewise, trees without adequate space for roots to grow (for example, small soil spaces surrounded by concrete or sidewalks) are prone to blowing over. Trees planted in shallow soils are more prone to blow over than trees rooted more deeply. Large and recently planted trees tend to get blown over more often than healthy, young, and well established trees.

Pruning is very important to wind resistance. Trees that have been pruned on a regular basis are less likely to suffer wind damage than neglected, unpruned trees. Pruning

should be done by professional arborists or trained personnel.

The urban forest is susceptible to wind damage. The faster the winds blow (measured by miles per hour) the greater the chance a tree will be blown over. A healthy tree that may withstand 85 mph winds may not resist hurricane force winds of 145 mph. Although some trees are more wind resistant than others, there is no tree that is absolutely wind proof. Different tree species vary in their resistance to wind. Tree characteristics, such as form, size, age, condition of the crown, trunk, root system, and density of the wood play an important role in wind resistance.

Trees can be damaged by winds in several ways. Most often trees may have their branches broken, their leaves lost, or their bark stripped off. Trees can also be blown over or have their trunks broken. When a large tree falls over, it can damage other trees nearby that may be perfectly healthy. Other trees may uproot, (exposing their root system partially or completely), or lean over.

While hurricanes and strong winds affect the urban forest negatively, only the trees that are close to a house or other structure have the potential of damaging something if they fall over. It is important to keep those trees strong and healthy.

Tables of Wind Resistance For Tree Species

For Central and North Florida

High	Medium	Low
live oak	wax myrtle	sand pine
sabal palm	longleaf pine	spruce pine
southern magnolia	slash pine	loblolly pine
bald cypress	shumard oak	laurel oak
crape myrtle	turkey oak	water oak
dogwood	silver maple	southern red cedar
sweet gum	Washington fan palm	Carolina laurel cherry
American holly	pignut hickory	tulip poplar
Canary Island date palm	swamp chestnut oak	red maple
myrtle oak	sycamore	pecan

For South Florida

High	Medium	Low
live oak	wax myrtle	sand pine
sabal palm	Washington fan palm	loblolly pine
southern magnolia	sycamore	laurel oak
bald cypress	mango	water oak
crape myrtle	royal poinciana	southern red cedar
dogwood	tropical almond	Carolina laurel cherry
sweet gum	coconut palm	tulip poplar
American holly	avocado	red maple
Canary Island date palm	mahogany	silk oak
gumbo limbo	white cedar	black olive
boxleaf stopper	FL royal palm	leyland cypress
pygmy date palm		Hong-Kong orchid
areca palm		golden trumpet
Senegal date palm		African tulip tree
sand live oak		Norfolk Island pine
buttonwood		queen palm
FL and Key thatch palms		weeping fig
chinese fan palm		

Tables of Wind Resistance For Tree Species

Common Name	Scientific Name
southern magnolia	<i>Magnolia grandiflora</i>
bald cypress	<i>Taxodium distichum</i>
crape myrtle	<i>Lagerstroemia indica</i>
dogwood	<i>Cornus florida</i>
sweet gum	<i>Liquidambar styraciflua</i>
American holly	<i>Ilex opaca</i>
wax myrtle	<i>Myrica cerifera</i>
longleaf pine	<i>Pinus palustris</i>
slash pine	<i>Pinus elliottii</i>
loblolly pine	<i>Pinus taeda</i>
sand pine	<i>Pinus clausa</i>
spruce pine	<i>Pinus glabra</i>
dahoon holly	<i>Ilex cassine</i>
red maple	<i>Acer rubrum</i>
silver maple	<i>Acer saccharinum</i>
pignut hickory	<i>Carya glabra</i>
live oak	<i>Quercus virginiana</i>
laurel oak	<i>Quercus laurifolia</i>
water oak	<i>Quercus nigra</i>
turkey oak	<i>Quercus laevis</i>
myrtle oak	<i>Quercus myrtifolia</i>
Shumard oak	<i>Quercus shumardii</i>
sand live oak	<i>Quercus geminata</i>
swamp chestnut oak	<i>Quercus michauxii</i>
southern red cedar	<i>Juniperus silicicola</i>
Carolina laurel cherry	<i>Prunus caroliniana</i>
sycamore	<i>Platanus occidentalis</i>
tulip poplar	<i>Liriodendron tulipifera</i>

Common Name	Scientific Name
gumbo limbo	<i>Bursera simarouba</i>
boxleaf stopper	<i>Eugenia spp</i>
mango	<i>Mangifera indica</i>
royal poinciana	<i>Delonix regia</i>
tropical almond	<i>Terminalia cattaapa</i>
mahogany	<i>Swetenia mahagony</i>
white cedar	<i>Tabebuia heterophylla</i>
citrus	<i>Citrus spp</i>
black olive	<i>Bucida buceras</i>
avocado	<i>Persea americana</i>
Hong-Kong orchid	<i>Bauhinia variegata</i>
trumpet tree	<i>Tabebuia aurea</i>
African tulip tree	<i>Spathodea campanulata</i>
Norfolk Island pine	<i>Araucaria heterophylla</i>
silk oak	<i>Grevillea robusta</i>
pecan	<i>Carya illinoensis</i>
weeping fig	<i>Ficus benjamina</i>
leyland cypress	<i>X Cupressocyparis leylandii</i>
buttonwood	<i>Conocarpus erectus</i>
coconut palm	<i>Cocos nucifera</i>
royal palm	<i>Roystonea elata</i>
pygmy date palm	<i>Phoenix roebelenii</i>
queen palm	<i>Syagrus romanzoffianum</i>
areca palm	<i>Chrysalidocarpus lutescens</i>
Senegal date palm	<i>Phoenix reclinata</i>
Washington fan palm	<i>Washingtonia robusta</i>
sabal palm	<i>Sabal palmetto</i>
chinese fan palm	<i>Livistona chinensis</i>

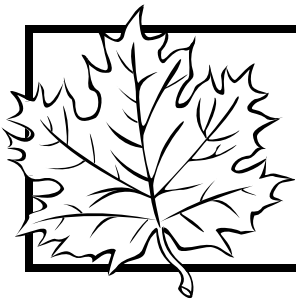

Soil Stories

PLT activity #70

Goal 3: Opportunities for Action

Concept: Forest Health

Overview

Good soil is essential for healthy trees. Compacted soil can be found in most urban areas. Extreme compaction decreases a tree's ability to absorb needed nutrients and water. In this extension to the PLT Activity #70, *Soil Stories*, students will measure soil compaction at their study area.

Objectives

Students will be able to **1)** observe soil in their area; **2)** measure compaction by pouring water in experimental plots; and **3)** state how soil compaction affects tree health.

Materials

Each Group Needs: 1 empty 15 oz. can, can opener, measuring cup, container for water, ruler, watch with second hand, rubber mallet, data sheet and copy of page 297 in *PLT PreK-8 Activity Guide*.

Grade Level: 5 – 8

Time Consideration: 1 day

Subject Areas: Science, Math

Skills: Observing, Measuring, Comparing, Contrasting, Analyzing, and Concluding

Relevant Standards:

SC.D.2.3 – The student understands the need for protection of natural systems on Earth

SC.H.1.2 – The student uses scientific method and habits of mind to solve problems

MA.A.4.2, MA.A.4.3 – The student uses estimation, in problem solving and computation

Background

Soil is composed of particles of different sizes and spaces containing air or water. A compacted soil has less space for water and air. Compacted soils are common in urban areas due to human activities. Compaction can be caused by heavy equipment, vehicles, and people passing over the same ground again and again. If soil particles are too close together it will be difficult for the tree's roots to grow. Excessive compaction can cause root damage. The combination of all of these factors can contribute to a decline in tree health.

Getting Ready

- 1) Visit the site and identify areas of probable compaction and areas near trees. If you have conducted the *Taking Inventory and Mapping* activity, you can hang up the class map to show where student groups will do their testing. You can put clear projection sheet paper on top of the map so students can mark where they found sites with compacted soils.
- 2) Ask students to collect empty 15 oz. cans and bring them to class. When there are enough for each group, you are ready.
- 3) Each group should have a can. Remove both ends of the can. Make sure there are no sharp edges.
- 4) Each group will need a container of water.
- 5) Copy page 297 in PLT book. Go over different types of soil types. Note that water will take longer to seep into clay soil.

Pre-Activity Questions

- 1) What do trees need to grow?
- 2) How does compacted soil affect a tree's ability to attain water and nutrients?
- 3) Where do you think compaction will occur at your site?
- 4) **Define:** compaction, clay, sand, and loam.

Doing the Activity

- 1) Ask students to observe the soil at their site and make sure they all test compaction in the same type of soil: clay, sand, or loam.
- 2) Divide students into groups. Hand out a can, a pitcher of water, measuring cup, and data sheets to each group. Make sure someone has a watch that measures seconds.
- 3) Each student should choose a role: note-taker, timer, ruler-holder, or water pourer.
- 4) Each student group should be assigned a site. For example:
 - A= Under a Tree's Canopy + On a Path
 - B= Under a Tree's Canopy + Away from Path
 - C= Away from Tree + Away from Path

Use picture below to help designate experimental plot locations.

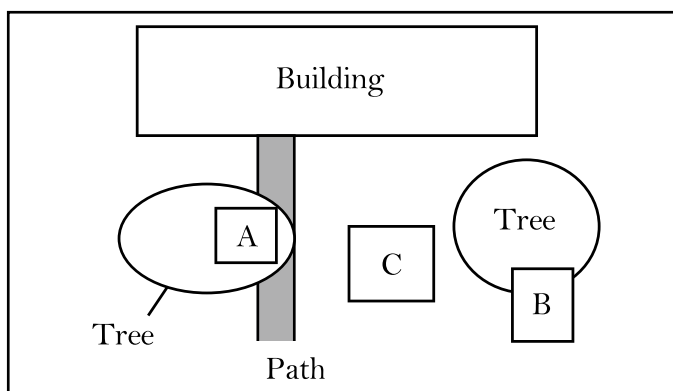

- 5) Mark a line, 2 inches from the bottom of the can. Using a rubber mallet, pound the can into the soil so you do not see the 2-inch line on your can.
- 6) Hold a ruler upright inside the can while another person pours 1 cup of water into the can.
- 7) Immediately after the water is poured, record the depth of water, then 30 seconds later, then 60 seconds, and so on until you reach 5 minutes.

- 8) Each student group should report their findings. As a class, compare different sites.

Post-Activity Questions

- 1) Where did water filter into the ground the quickest?
- 2) Where did water filter into the ground the slowest?
- 3) Where did most of the compaction occur?
- 4) How did compaction occur?
- 5) How might trees be affected by compaction?
- 6) What can you do to minimize compaction at your site? (*stay on paths, designate a path, or create signage, mulch paths*)

Assessment

- Collect completed data sheets to determine if students accurately assessed compaction at their site.
- Have students write a short paragraph describing how trees are influenced by compaction.

Extension

Find out more about the soil type(s) in your county and research which type of trees will grow well there. This type of information can be found in your county's soil survey document. Contact your county soil agent for more information.

Related PLT Activities

Every Tree for Itself #27
Trees in Trouble #77

References

Coder, K.D. 2001. Chapter 7: Site Assessment in Restoring the Urban Forest Ecosystem. IFAS, Cooperative Extension Service, University of Florida. FOR 96/ FRO71
<http://edis.ifas.ufl.edu/FRO71>

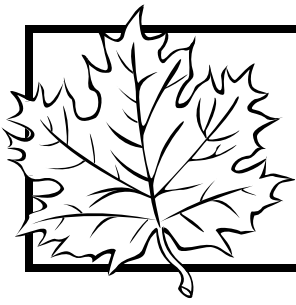

Every Tree for Itself

PLT activity #27

Goal 3: Opportunities for Action

Concept: Forest Health

Overview

One way of enhancing our urban forest is to help prolong the life of the trees we already have. In this extension to PLT Activity #27 *Every Tree for Itself*, students will recognize the many difficulties urban trees face and identify good and poor tree care practices.

Objective

Students will be able to describe one way of prolonging the life of an urban tree.

Materials

Copy and cut urban tree scenarios, poker chips (3 colors).

Grade Level: 3 – 8

Time Consideration: 30 minutes

Subject Areas: Science

Skills: Role playing, Comparing, Contrasting, Analyzing, and Concluding

Relevant Standards:

SC.D.2.2, SC.D.2.3 – The student understands the need for protection of natural systems on Earth

SC.G.1.2, SC.G.1.3 – The student understands the competitive, independent cyclic nature of living things in the environment.

Background

The life span of most urban trees is shorter than their capacity to live. Replacing urban trees can be economically, socially, and environmentally expensive. The more trees we have the more they may provide potential benefits to our communities thereby mitigating the negative effects of urban development.

In this urban extension to *Every Tree for Itself*, students will recognize the many difficulties urban trees face and relate them to the tree's life span. This will contribute to a discussion of how good tree care practices can replace poor ones to help prolong the life of our urban trees.

Doing the Activity

- 1) Conduct *Every Tree for Itself* as indicated in the *PreK-8 Activity Guide*. Once completed, ask students to think about how these trees would survive in a town or city.
- 2) Give each student a tree scenario that will determine her/his fate as an urban tree.
- 3) Repeat *Every Tree for Itself* using the urban tree scenarios. Ten negative scenarios describe situations that suppress a tree's ability to grow. For each negative scenario students will be given a limitation such as standing on one foot, using one arm, or sitting down. Five positive scenarios indicate how we can help urban trees thrive.
- 4) Students who do not have the essential requirements for growth (i.e., enough poker chips) are considered unhealthy and will be removed for safety or aesthetic reasons.
- 5) Ask those students to explain why they did not thrive in the city.

Post-Activity Discussion

- 1) What were some of the difficulties urban trees face?
- 2) Was there a difference in the number of trees that survived in the two rounds of this activity?
- 3) How has the space between the trees changed?
- 4) What are examples of good tree care practices that people can use to prolong the life of their tree?

Assessment

Ask students to write a short paragraph describing specific strategies we can use to help urban trees live longer.

Related PLT Activities

Plant a Tree #31
Trees in Trouble #77

References

Fazio, J. 1996. How to Kill a Tree. Tree City USA Bulletin 14, The National Arbor Day Foundation.

Urban Tree Scenarios

Right Tree in the Right Place

The person who planted you asked the nursery worker the right questions. They asked about how to plant you, how big you will get, and how to maintain you. *Since you are best suited to this area you will live a long healthy life.*

Under the Utility Wires

You're much too tall and grow into the telephone wires and power lines. The utility arborist has permission to chop off a portion of your canopy making it harder to photosynthesize. *Hold one arm behind your back.*

Planted Right

You were planted with care in a hole no deeper than your root ball, the soil is rich in nutrients, and you have enough light, water, and space to grow tall and strong. *You are flourishing.*

Sensitive Roots

Before you were planted, someone left you in the sun and your sensitive roots became damaged. Not having a good root system makes it difficult to get nutrients from the ground. *Stand on one foot.*

Over-Fertilized

No one bothered to test the soil before planting you. If they had, they wouldn't have added all of that fertilizer when you were planted. This excess fertilizer burned your roots. *Sit down.*

Guides that Constrict

The wires that guided your growth are now constricting you and cutting into your bark. This wound makes it easier for microbes and insects to enter your phloem and xylem. *Put one hand in your pocket.*

Compaction and Root Wounding

Your roots are trampled every day by cars that park underneath your canopy. This compacts the soil and makes it harder to bring in water and nutrients from the ground. *Stand on one foot.*

Followed Fertilizer Directions

The person who planted you read the fertilizer labels and followed the advice of their local extension agent. *You are thriving.*

Lawn Maintenance Trouble

Between the weed whacker and the lawn mower the lower part of your trunk is damaged. A fungus has moved into your wound. *Stand on one foot.*

Hanging Out with the Neighbors

Your canopy is shading the neighbor's pool. They get permission from your owner to cut back limbs that hang over the fence. *Put one hand in your pocket.*

Everywhere is a Parking Lot

The constant gathering of cars, people, and temporary construction equipment starts restricting your fine root hairs' ability to absorb needed nutrients. *Stand on one foot.*

Mulching with Care

Your conscientious owner has placed a layer of mulch around your base and not directly on your trunk to control weeds, retain moisture, and keep lawnmowers away from your bark. *You are doing well.*

Good Barriers make Good Neighbors to Vehicles

In order to protect your root system, the construction crew set up a barrier to prevent heavy vehicles and equipment from compacting the soil within your dripline. *You are thriving despite the construction.*

Pave-Me-In

The city operations department put a sidewalk over your roots. In order to make the sidewalk level they cut several large roots. This not only weakens your balance it also decreases your ability to move nutrients. *Kneel and put one hand behind your back.*

Too Big for the Planter

Your owner planted you in a small container. It was okay when you were a young sapling but now that you are much older the small space keeps your roots from spreading. *Sit down.*

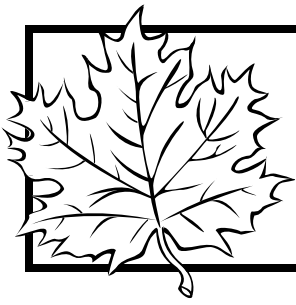

Who Works in This Forest?

PLT activity #34

Goal 3: Opportunities for Action

Concept: Community Projects

Overview

Many people work in the urban forest. Some of these people are trained in forestry and can work in a rural forest, but many have the skills and background specific to urban areas. In this urban forest extension of *Who Works in This Forest?*, Activity #34 in *PLT PreK-8 Activity Guide*, students will learn about urban forest career profiles to help them gain an overview of who helps maintain this urban forest.

Objectives

Students will be able to **1)** describe how various professionals care for the urban forests; and **2)** explore a variety of jobs that are directly related to your community.

Materials

A copy of the career profiles for each student, a phone book, and Internet.

Grade Level: 3-5

Time Considerations: 1-3 weeks

Subject Areas: Language Arts and Social Studies

Skills: Listening, Discussing, and Questioning

Relevant Standards:

L.A.C.1.2 – The student uses listening strategies effectively

S.S.B.2.2 – The student understands the interactions of people and the physical environment

Getting Ready

Make copies of the Urban Forest Career Profile for each student on page 66.

Pre-Activity Questions

- 1) Do urban forests require people to take care of them?
- 2) What work is necessary to take care of an urban forest?

Doing the Activity

- 1) Tell students that they will be reading job descriptions of several people who do particular types of work. Students should read the brief descriptions and decide which jobs are necessary for caring for the urban forest. They should explain their choices on a separate piece of paper.
- 2) Go over the job descriptions with the students. Have them share their choices and the reasons for those choices. By the end of the discussion, all students should realize that every job on the page is helpful in conserving and caring for the urban forest.
- 3) Assign students into one of six teams. Assign a different career profile from the ones discussed to each group.
- 4) Each group will develop a list of questions to ask this professional about his/her job.
- 5) Allow students to use a phonebook or the Internet to find the name and address of a person that matches their assigned career profile. Student groups will write a letter to this person explaining that they are learning about urban forestry careers. This letter should include their list of questions and school contact information. You can also have students contact this person for an interview.
- 6) Students should present their findings to the rest of the class after they receive responses back from their letters or they have completed an interview.

Assessment

Ask students to write a story as if they were one of the urban forest professionals discussed during this activity.

Enrichment

Invite several people whose jobs are related to urban forestry to come and speak to the class.

Related PLT Activities

A Forest of Many Uses #32

Juan – Environmental Planner

I consult with the public, government, interest groups, and industry to create a land use plan for the community. I help plan public facilities such as transportation systems, recreation areas, and urban renewal projects and pay special attention to the role of trees in each project. If my work goes well I can help create a place where our natural heritage and our built environment will exist together for future generations.

Edna – Utility Arborist

I patrol areas where there are power lines and identify limbs to trim to prevent trees from growing over the line. I educate the public to choose the most appropriate tree or shrub to plant near a power line so I won't have to prune, remove, or replace so many trees. Sometimes people don't like the sheared look of trees near powerlines, but they like losing power even less. Broken powerlines can start wildfires, so we take this job seriously.

Maria – Urban Forester

I help maintain the health of each tree and look for ways to improve the health of the entire urban

forest. To accomplish this, I work with a variety of professionals and organizations. My work includes trying to positively influence planners and policy makers to keep healthy urban trees. I may also work with school teachers on tree planting projects. Often, I work alongside park maintenance crews to recommend the best way to minimize the effects of construction and give advice on the best tree-care practices for our urban trees.

Jeanette – Urban Forest Research Scientist

I work for the U.S. Forest Service to answer questions about urban trees. I'm working to improve the way we design and manage urban forests, so we can have better forests. I look for ways to promote better air, water quality, safety, and aesthetics. My interest in trees helps others understand and apply what will work in their urban forest.

David – Groundskeeper

I use a rake, pruning shears, weed whacker, and a saw at work. These tools all help me maintain the area I landscape. Using the right techniques, I can enhance the health of a tree and protect it from people, mowers, insects, and other things that may harm it.

Dwight – Extension Agent

As an extension agent, I translate research findings so people can make the best choices for their trees. Since the majority of the urban forest is actually on private land, it is my duty to educate the public about environmentally friendly landscaping. This will help protect natural resources such as our waterways and keep the urban forest healthy.

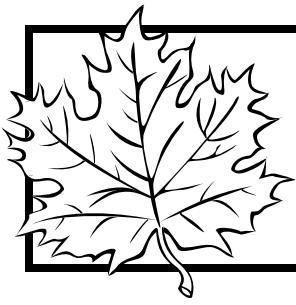

Trees as Habitats

PLT activity #22

Goal 3: Opportunities for Action

Concept: Community Projects

Overview

Animals respond to the decisions people make in the urban landscape. A variety of animals can live in an urban area if people choose to preserve, maintain, or create a suitable habitat for them. In this urban forest extension of *Trees as Habitats*, Activity #22 in *PLT PreK-8 Activity Guide*, students will look for the basic elements all animals need, then create a plan that provides those elements for native animals that are not present in their area.

Objectives

Students will be able to **1)** name four basic elements all animals need in their habitat; **2)** describe how the structure of the urban forest with its tree, shrub, and herbaceous plant layer can support wildlife needs; **3)** identify native animals that can live in their urban area through research; and **4)** illustrate how an urban forest can make a suitable environment for wildlife by creating a plan to enhance the urban forest.

Materials

Data sheets, clipboards, binoculars, animal guide books, hand-lenses, and Internet or library.

Grade Level: 6 – 8

Time Considerations: 1 day

Subject Area: Science

Skills: Observing, Counting, Comparing, Contrasting, and Research

Relevant Standards:

SC.G.1.3 – The student understands the competitive interdependent cyclic nature of living things in the environment

Background

The urban forest can be a suitable habitat for wildlife if animals can attain all four essential elements: food, water, shelter, and space. Trees and other vegetation can provide food for a variety of plant-eating organisms. Every animal needs water. They can get it from the food they eat, shallow surfaces such as puddles, or dew on the ground. However, finding clean, fresh water can be harder than finding food in some urban areas. Shelter is also important to wildlife. The urban forest can be a good place for wildlife to hide from predators, raise young, rest, or escape from harsh weather. Although dead trees might seem untidy in the urban landscape, if they are unlikely to hurt anyone when they fall, they can be a home for a variety of animals. The amount of space for wildlife is often a limiting factor in most urban environments. This includes both vertical and horizontal space.

Florida is one of the most biologically diverse states in North America. It has more than 1,200 known native species not including invertebrates. Five hundred of these animals spend their entire life in salt or freshwater while the other 700 birds, mammals, reptiles, and amphibians live in terrestrial habitats during part of their life cycle. Due to rapid urbanization, Florida has experienced unprecedented changes in its natural environment. Conditions to support wading birds have been replaced to such a great extent that it may be more common to see gray squirrels or mockingbirds where once there were great blue herons and wood storks.

However, people can make decisions to promote wildlife in the urban landscape by planning the urban forest to accommodate wildlife, with food, cover, water, and space. To do this, the size, structure, and composition of the urban forest

should be considered. For example, forests should have several layers and a diversity of plants. Tree, shrub, and ground level plant layers may help satisfy many of the needs for wildlife for food or space. People can choose to include water in an urban area by adding bird-baths or artificial ponds, or maintaining lakes and streams. Although loss of space due to urbanization is one of the most critical problems facing wildlife, people can support urban planning designs that include a space for animals. These include protecting natural corridors along water-ways or creating corridors along railroads and greenways that connect parks and preserves.

The urban forest can be a suitable habitat for a variety of animals. People can help promote the population and diversity of animals through the enhancement of their urban forest.

Getting Ready

- 1) Educators should preview their site to assess places for students to investigate.
- 2) Look up animals that should exist in the area. Provide animal books and guidebooks for students to use in their research. It may be helpful to have animal tracking books available for students.

Pre-Activity Questions

- 1) What would happen if there were absolutely no animals where you live, work, learn, and play? What does this tell you about the environment?
- 2) How has development changed the landscape?
- 3) **Define:** biodiversity, camouflage, habitat, snag, and wildlife corridor.

Doing the Activity

- 1) Conduct *Trees as Habitats* Activity #22. Explain the concept of camouflage and tell students not to be discouraged if they do not see animals.
- 2) Explain to students they will be looking for four elements that animals need to survive and three layers. Use observation data sheet.
- 3) Assign students into groups to design a wildlife accommodation plan and distribute that worksheet.

- 4) Explain to students that their plans to encourage wildlife should consist of a plan for providing food, water, cover, and living space for the animal and creating an attractive space for people. Suggest researching animals such as birds, butterflies, small mammals, snakes, frogs, and fish.

- 5) Students are encouraged to provide solutions to increase wildlife at their site. This may include building birdhouses, creating ponds, as well as planting trees, shrubs, and herbaceous plants.

Post-Activity Questions

- 1) Name one animal that could live at your site. What could it eat? Where could it get water, shelter, and how much territory do you believe it occupies?
- 2) What actions can people take to enhance wildlife in the area?
- 3) For some people, certain animals are considered a nuisance: for example, raccoons are sometimes found rummaging through garbage. Name some of these animals and how people can lessen the negative effects of wildlife. Would your plan to encourage wildlife also support nuisance species?
- 4) How can the size, structure, and composition of the urban forest promote wildlife?

Assessment

Ask students to list four elements all animals need when choosing a habitat; then ask them to write a short paragraph on how the size, structure, and composition of an urban forest can be enhanced to promote wildlife in their urban area.

Related PLT Activities

The Forest of S.T. Shrew #8
School Yard Safari #46
The Fallen Log #23
A Forest of Many Uses #32

Reference

Schaefer, J. 1996. Addressing Wildlife Needs in Construction Site Management Plans. IFAS, Cooperative Extension Service. University of Florida. SSWEC-114/ UW105
<http://edis.ifas.ufl.edu/UW070>

Observation Data Sheet

Urban Forest Extension: Trees as Habitats

Observe the size, structure, and composition of the urban forest for its ability to support wildlife.

Observe your urban forest.

1) Do you have tall trees?

Yes No

2) Do you have medium-sized shrubs?

Yes No

3) Do you have low ground plants?

Yes No

4) Are there places where you have a mixture of trees, shrubs, and ground level plants?

Yes No

5) How much diversity do you find in the tree, shrub, and ground layers?

6) What type of fruits do you see on or around different plants?



Urban Forest Extension: Trees as Habitats

Wildlife Accommodation Plan

Directions: Research an animal that can live in your urban area. Consider food, water, cover, and living space. This plan has to satisfy both people and the animal.

Name an animal you would like to see in your urban area. Does it live in the region?

What does it eat? _____

Do you have this food source on your site? Yes No

If no, how will you provide it? _____

Where will your animal get water? _____

Do you have it on your site? Yes No

If no, what can you do so that your animal has water?

Where can it find shelter? _____

How much space does it need? _____

What kinds of trees, shrubs, or ground plants should be included to ensure food and shelter?

How can you improve the size, structure, and composition of your urban forest to accommodate wildlife?
(Provide tree, shrub, and ground plant layers)

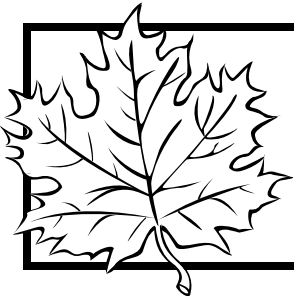

Modifications to PLT Activities to Enhance Opportunities for Action to Help the Urban Forest

Forest Consequences, Activity #33

List the many reasons why we should protect an urban forest and the difficulties they face. Create a mural or a poster about the benefits of an urban forest and present it on Arbor Day, Earth Day, or any other special event.

Power of Print, Activity #59

The words people use in printed materials such as newspapers, magazines, and the Internet can sway readers' opinions and beliefs. Students could be encouraged to analyze words used to describe an urban environmental problem.

Publicize It!, Activity #60

Ask students to create a public service announcement, signage, brochures, or a computer presentation about the benefits of an urban forest.

Tree Lifecycle, Activity #79

Explain an urban tree's life through art and drama.

Participate in Community Projects

There are plenty of existing projects in your local area. They can range from working with a local nature center, a neighborhood tree planting program or a community habitat restoration program. Before creating a new project find out who and what is happening in your local area.

Florida Division of Forestry

<http://www.fl-dof.com/>

Check out volunteer opportunities to help our state forest agency meet its mission to protect and manage Florida's forest resources for future generations.

Broward Urban Forest Initiative

<http://www.co.broward.fl.us//bio/uplands.htm>

One of the goals for Broward County is to increase the tree canopy through public education, tree plantings, tree give-aways, mapping, and monitoring the percent canopy.

Greenscape of Jacksonville, Inc.

<http://www.greenscapeofjacksonville.org/>

Get your hands dirty and participate in a tree planting activity.

Department of Environmental Resource Management—Miami

http://www.miamidade.gov/derm/events_volunteer.asp

Help Miami bolster the condition of its community's tree canopy. Participate in its adopt-a-tree programs.

<http://www.miamidade.gov/derm/adoptatree/>

Plant a Tree, Activity #31

This activity includes steps on how to plant a tree. Use the following Web sites and resources to help guide your planting activity.

Grades & Standards for Nursery Plants

http://prohort.ifas.ufl.edu/grades_standards.htm

Good advice on how to select, plant, and care for trees.

The Institute of Food and Agricultural Sciences (IFAS)

http://edis.ifas.ufl.edu/TOPIC_Landscape_Plants

Look up what kinds of trees and other plants work well in your area.

Planning the Ideal Community, Activity #55

In this activity, students consider what a community needs to be as a good place to live. In addition, have students notice the trees and other vegetation as they travel in their community.

There Ought to be a Law, Activity #58

In this activity students could research local laws that affect the urban forest – tree ordinances and development or prescribed burning.

Improve Your Place, Activity #96

Students can undertake a variety of projects to improve the urban forest. One important project could be to help reduce invasions of non-native species. Learn about invasive species in your area and organize an action activity to remove them. Visit the Florida Exotic Pest Plant Council (<http://www.fleppc.org/websites.htm>) and the University of Florida's EDIS Web site (<http://edis.ifas.ufl.edu/>) for additional information.



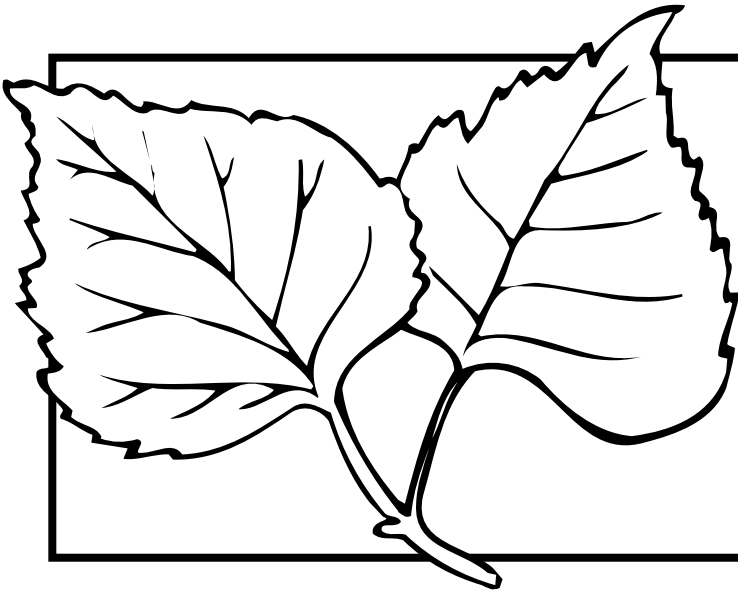

Section 4

Urban Forest Resources

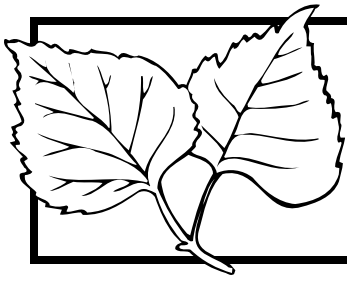

Urban Forest Resources

USDA Forest Service Southern Region

The mission of the Urban and Community Forestry (U&CF) Program is to promote conservation and management of forests and related natural resources in cities, with a focus on obtaining the highest social, environmental, psychological, and economic benefit.

<http://www.urbanforestrysouth.org>

School of Forest Resources and Conservation, Institute of Food and Agricultural Sciences, University of Florida

Give Forests a Hand, Leader's Guide: A youth program for environmental action and community service. Cooperative Extension Service. University of Florida. Publication by Janice Easton, Martha Monroe and Lizzie Peme. 2002. Circular 1270/FR118 <http://edis.ifas.ufl.edu/FR118>

Give Forests a Hand, Youth Action Guide: A workbook just for youth that complements the Leader's Guide. Cooperative Extension Service. University of Florida. Publication by Janice Easton, Martha Monroe and Alison Bowers. 2002. Circular 1269/FR117 <http://edis.ifas.ufl.edu/FR117>

Project Learning Tree

Project Learning Tree (PLT) is an environmental education program for students from Pre-kindergarten to grade twelve. This environmental education program is supported by the American Forest Foundation and widely used nationally and internationally.

Project Learning Tree PreK-8 Environmental Education Activity Guide

GreenWorks! – Environmental Education Community Action Component

<http://www.plt.org>

PLT in Florida <http://sfrc.ufl.edu/plt>

4-H

4-H is the educational branch of the Cooperative Extension Service that teaches young people about the environment. This program is part of the United States Department of Agriculture and offices are found in most states across the nation. <http://4h.ifas.ufl.edu/index1.htm>

Web sites for Urban and Community Forestry

TreeLink

<http://www.treelink.org/>

American Forests

<http://www.americanforests.org/>

National Arbor Day Foundation

<http://www.arborday.org>

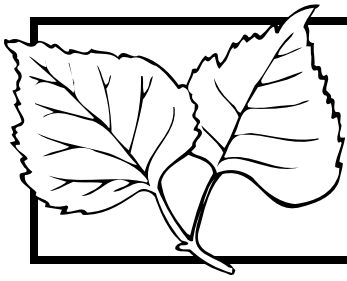

Urban Forest Glossary of Terms

Ambient air temperature*

The temperature of the surrounding air.

Aquifer*

Rock substrate that holds water or through which water flows.

Arborist*

A specialist in the care and maintenance of trees.

Biodiversity*

The variety of life and all the processes that keep life functioning. It includes the variety of different species (plants, animals including humans, microbes, and other organisms), the genes they contain, and the structural diversity in ecosystems.

Camouflage*

The natural coloring or form of an animal which allows it to blend in with its surroundings.

Canopy*

The percent of land area covered by tree crowns.

Clay*

A very fine-grained soil that can stick to your hands when moist. The heaviest soil classification, composed of closely packed particles that allow less water and air movement through the soil.

Circumference*

The perimeter of a circle.

Community

A group of living organisms (plants, animals, microbes) that interact with each other in energy flow and nutrient cycling processes in an ecosystem. The biotic component of a particular system.

Compaction*

An increase in soil density caused by foot, motor traffic, or heavy machinery.

Cost-benefit analysis*

The determination and comparison of the costs and benefits of an activity to evaluate its economic viability.

Cover

Plants and structures in the urban ecosystem that provide protection from weather and predators for an animal.

Crown

Upper portion of the tree, including leaves, twigs, and branches.

Diameter at Breast Height (DBH)*

Tree size, based on its diameter when measured 4.5 feet above ground.

Die-Back*

Death of twigs and branches in the outer portion of a tree's crown.

Erosion

The action of water and wind that wears away rock and moves soil downstream.

Evergreen*

A plant which retains its needles or leaves for more than one growing season.

Exotic

Plant or animal species introduced into an area where it does not occur naturally; either intentionally or accidentally.

Forest structure

The quality and abundance of the various vegetation layers (canopy, subcanopy, shrub layer, and ground cover) and the presence of dead logs and snags.

**Term used in an activity*

Gall

Abnormal growth of the leaves, twigs, or branches of a tree, often caused by an insect.

Habitat*

The area where a species lives or may potentially live because it provides all the life sustaining requirements for that particular species.

Impervious surface*

A hardened surface not easily penetrated by roots or water, such as pavement.

Infrastructure*

The basic structures needed for the operation of a society or organization. This can include buildings, streets, underground pipes, or overhead wires.

Invasive

An aggressive plant or animal population which out-competes other species in an ecosystem. It is a concern when plants and animals affect the integrity of natural systems.

Loam*

A rich soil consisting of a mixture of sand, clay, and decaying organic materials.

Map*

A diagram of an area showing the relationship of key features, such as roads, buildings, waterways, and trees.

Microclimate

The climate of small areas, such as under a tree or beside a building.

Particulate*

A very small solid suspended in air or water which can vary widely in size and shape.

Pavement

Asphalt or concrete that covers streets, parking lots, and sidewalks.

Photosynthesis

The production of carbohydrates and oxygen from carbon dioxide and water in plants. The reaction is driven by the energy of sunlight and catalyzed by chlorophyll.

Pollutant*

A harmful substance.

Psychological*

Having to do with the mind.

Quadrant*

A quarter of area or surface. Any one of the four approximately equal parts into which an area or a surface is divided by two real or imaginary perpendicular lines.

Resistance*

The ability of an organism to defend itself against a disease or withstand the effects of an outside force, i.e., wind.

Runoff*

Water from rain or irrigation that flows over the land's surface into ditches, rivers, streams, lakes, and oceans.

Sand*

Small loose grains of worn or disintegrated rock.

Sapling

A small, immature tree with a 1-5 inch DBH.

Snag*

A dead standing tree.

Social Scientist*

A person who studies how humans function and relate to others and the environment.

Susceptible*

To be easily affected by an external item, e.g., wind, insects, disease, and flooding.

Survey*

A tool to collect data about opinions or experiences of people, based on a series of questions.

Tree inventory*

Listing of trees and their characteristics.

Urban forest*

The trees and other vegetation within the built environment.

Urban forests are all the trees and other vegetation that grow in places where people live, work, and play from small communities in rural areas to large metropolitan cities. This includes trees on public and private land along streets, in residential areas, at parks, in commercial developments, and in other locations within a community.

Urban heat island effect*

The increase in temperature in cities, usually in the afternoon and evening, compared to surrounding rural lands.

Watershed*

The land area that delivers run-off water and sediment to a major river or stream and its tributaries.

Wildlife corridor*

Designated greenways that may be used by wildlife for nesting, feeding, or passage.

Wound

Cracks, seams, or holes in tree bark that can be caused by humans, weather, disease, or insects.



UF | UNIVERSITY *of*
FLORIDA
IFAS Extension

The Institute of Food and Agricultural Sciences (IFAS) is an Equal Opportunity Institution authorized to provide research, educational information and other services only to individuals and institutions that function with non-discrimination with respect to race, creed, color, religion, age, disability, sex, sexual orientation, marital status, national origin, political opinions or affiliations. U.S. Department of Agriculture, Cooperative Extension Service, University of Florida, IFAS, Florida A. & M. University Cooperative Extension Program, and Boards of County Commissioners Cooperating.

Florida Cooperative Extension Service/Institute of Food and Agricultural Sciences/University of Florida/Larry R. Arrington, Dean